

C7-CA Series Data Sheet

PN: 602346134, Model: C7-S8-3070-CA-S8.5-T-5G

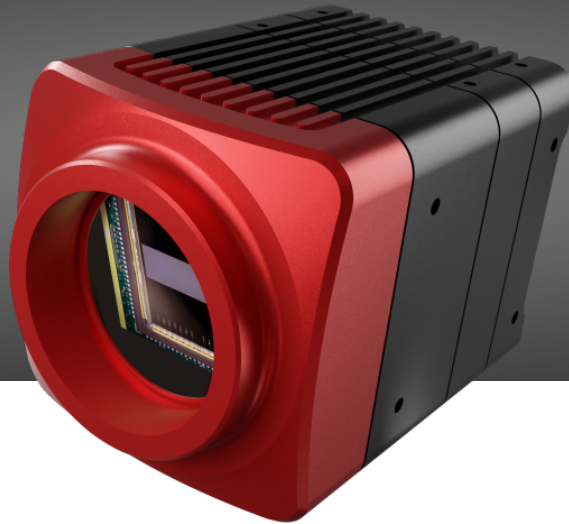

The CA series stands out with maximum flexibility and powerful performance for a wide range of industrial image processing applications. With a resolution of 3072 pixels, it is ideally suited for a variety of demanding tasks. Integration into existing systems is exceptionally fast and convenient, thanks to the advanced 5G ethernet interface. The innovative LaserLink interface allows common lasers to be connected directly to the camera, further expanding the range of possible applications. Support for the GenICam standard, as well as various Scheimpflug configurations and model variants, make the CA series the ideal choice for complex multi-sensor applications.

- **High-resolution 3D industrial camera with 3072 pixels**
- **Versatile for a wide range of industrial applications**
- **Ultra-fast 5G Ethernet interface**
- **Direct connection of common lasers via LaserLink interface**
- **Input and encoder signal levels (TTL or HTL) can be configured**

 Visit our website

 Contact us

 Visit our Product Documentation

AT - Automation Technology GmbH
Hermann-Bössow-Straße 6-8
23843 Bad Oldesloe
Germany

AT - Automation Technology, Inc.
380 Main Street, Suite 203
Stoneham, MA 02180
United States

www.at-sensors.com
support@automationtechnology.de
+49 (0)4531 / 88011-42

Model Information

Model name	C7-S8-3070-CA-S8.5-T-5G
Part number	602346134

Detector/Performance specifications

Detector	CMOS Global Shutter
Resolution	3072 x 1020 pixels
Physical size	20.275 x 6.732 mm
Pixel size	6.6 x 6.6 μ m
Points per profile	3072
Profile speed at 200 rows	4798.0 Hz
Maximum profile speed	66489.0 Hz

Interface specifications

Ethernet	5GBase-T up to 5000.0 Mbit/s
Encoder	A, B, Z RS-422 HTL TTL
Digital inputs	2x isolated digital inputs 5V - 24V DC
Digital outputs	2x isolated digital outputs 5V - 24V DC
Analog output	1x analog output 0V - 5V DC

Electrical/Mechanical specifications

Power supply	12V - 24V DC 27V DC Max.
Power consumption	Max. 15 W
Connectors	Power&I/O: M12-Connector 17-pin A-coded Ethernet: M12-Connector 8-pin X-coded LaserLink: M8-Connector 8-pin A-coded
Housing material	Anodized aluminum
Dimensions (L x W x H)	79.8 mm x 55.0 mm x 55.0 mm
Weight	350.0 g
Internal Scheimpflug angle	8.5°
Lens mount	TFL-Mount

Environmental conditions

Temperature	Operating: 0 °C - +40 °C Storage: -20 °C - +80 °C
Humidity	20 % - 80 % (non-condensing)
Vibration resistance	Sinusoidal: DIN EN 60068-2-6:2008-10: 2g 10 Hz - 150 Hz Random: DIN EN 60068-2-64:2020-09: 7g 10 Hz - 500 Hz
Shock resistance	DIN EN 60068-2-27: 2010-02: 15 g 3 ms
Protection class	IP54 With optional lens protection IP67 According to IEC 60529

Software/Features

Supported standards	GenICam GigEVision
Firmware features	RegionTracking RegionSearch MultiRegion MultiPart AutoStart HistoryBuffer MultiSlope MultiPeak
Software	SolutionPackage MetrologyPackage cxSDK with wrappers for C, C++, Python and Matlab

 Visit our website

 Contact us

 Visit our Product Documentation

AT - Automation Technology GmbH
Hermann-Bössow-Straße 6-8
23843 Bad Oldesloe
Germany

AT - Automation Technology, Inc.
380 Main Street, Suite 203
Stoneham, MA 02180
United States

www.at-sensors.com
support@automationtechnology.de
+49 (0)4531 / 88011-42

Mechanical dimensions

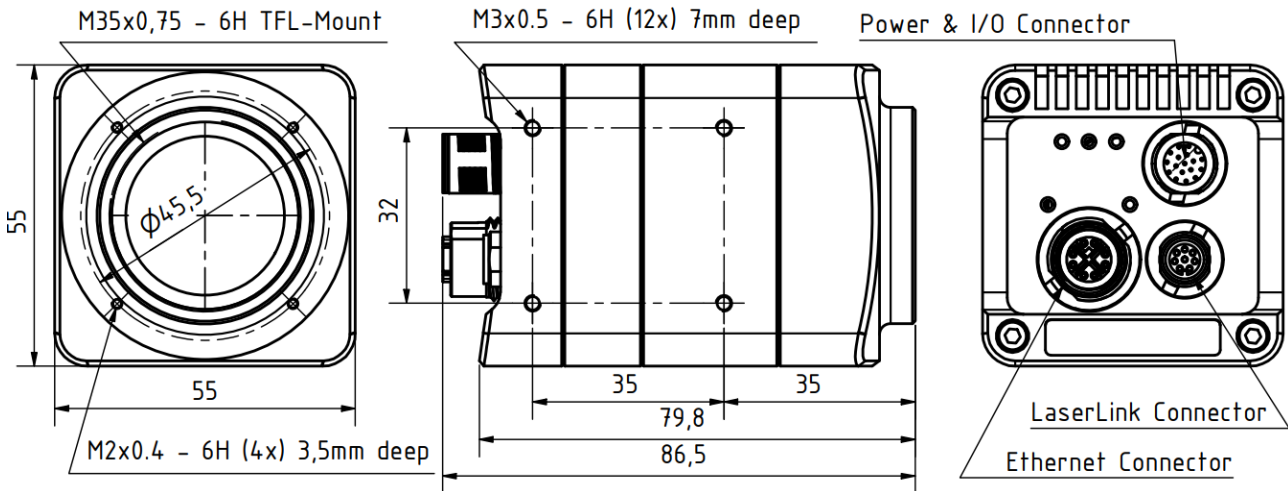

Connector layout and pin assignment

Power & I/O Connector: M12 17-Pin A-Coded Male

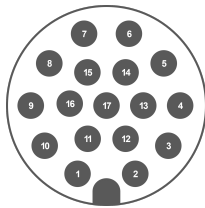

1	Z-	Encoder input Z- (RS-422, D-HTL)
2	L-VCC	Laser supply voltage (5-24V DC)
3	Z+	Encoder input Z+ (RS-422, TTL, D/SE-HTL)
4	B+	Encoder input B+ (RS-422, TTL, D/SE-HTL)
5	GND	Camera and Laser supply ground
6	B-	Encoder input B- (RS-422, D-HTL)
7	A-	Encoder input A- (RS-422, D-HTL)
8	VCC	Camera supply voltage
9	GND	Camera and Laser supply ground
10	A+	Encoder input A+ (RS-422, TTL, D/SE-HTL)
11	IN-GND	Reference ground for Encoder/Digital inputs
12	OUT2	Digital output 2, level defined by OUT-VCC
13	IN1	Digital input 1 (5-24V DC)
14	IN2	Digital input 2 (5-24V DC)
15	OUT-VCC	Output supply voltage (5-24V DC), refers to OUT-GND
16	OUT1	Digital output 1, level defined by OUT-VCC
17	OUT-GND	Reference ground for digital outputs
Shield	SHIELD	Connected to device housing

Ethernet Connector: M12 8-Pin X-Coded Female

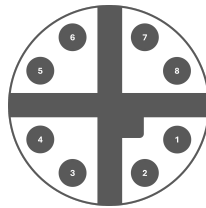

1	MDI1+	Data Pair 1, positive contact
2	MDI1-	Data Pair 1, negative contact
3	MDI2+	Data Pair 2, positive contact
4	MDI2-	Data Pair 2, negative contact
5	MDI4+	Data Pair 4, positive contact
6	MDI4-	Data Pair 4, negative contact
7	MDI3+	Data Pair 3, positive contact
8	MDI3-	Data Pair 3, negative contact
Shield	SHIELD	Connected to device housing

LaserLink Connector: M8 8-Pin A-Coded Female

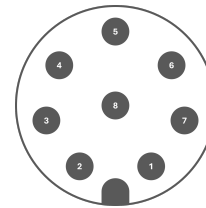

1	GND	Camera and Laser supply ground
2	VCC	Fused camera supply voltage output (5-24V DC)
3	L-VCC	Fused laser supply voltage output (5-24V DC)
4	AO	Analog output (0-5V)
5	DO	Digital output (5V)
6	TX	Transmit data output (RS-232)
7	RX	Receive data input (RS-232)
8	DI/AI	Digital/Analog input (0-5V)
Shield	SHIELD	Connected to device housing

Visit our website

Contact us

Visit our Product Documentation

AT - Automation Technology GmbH
Hermann-Bössow-Straße 6-8
23843 Bad Oldesloe
Germany

AT - Automation Technology, Inc.
380 Main Street, Suite 203
Stoneham, MA 02180
United States

www.at-sensors.com
support@automationtechnology.de
+49 (0)4531 / 88011-42