

CUSTOMIZATION
BUDGET **FLEXIBILITY**
PERFORMANCE



3D Laser Profile Sensors

TAILORED

3D Laser Profiler Sensors

SOLUTIONS

3D Vision Portfolio

The C6 and C7 series of laser profile sensors from AT is based on a new sensor platform that supports the latest industry standard GigE Vision/GenICam 3D with up to 5 Gbit/s. The laser profilers offer an impressive combination of extremely high-speed and high-precision resolution, enabling the profilers to enter worlds that 3D imaging has not seen before. They feature profile resolution up to 4096 points per profile and profile speed up to 140 kHz as well as high dynamic range 3D image acquisition. Available as compact sensor, MCS and 3D camera.



Compact Sensors (CS)

- ✓ Factory calibrated laser profile sensors
- ✓ Wide range of models with X-FOV 7 - 1290 mm
- ✓ Four different sensor resolutions available (1280, 2040, 3070, 4090)
- ✓ High industrial protection class IP67
- ✓ Available with various laser configurations
- ✓ Resolution Z up to 0.2 μm



Modular Compact Sensors (MCS)

- ✓ Factory assembled and calibrated 3D laser triangulation sensors consisting of sensor module, laser module and link module
- ✓ Customized Laser Profile Sensor designs without NRE or MOQ
- ✓ Four different sensor resolutions available (1280, 2040, 3070, 4090)
- ✓ Configurable according to application requirements like X-FOV, working distance, triangulation angle, number of points per profile, laser wavelength and laser safety class
- ✓ Dual-Head configuration possible for occlusion-free 3D scans
- ✓ High industrial protection class IP67



3D Cameras

- ✓ Designed for flexible laser triangulation setups with user-defined lasers and lenses
- ✓ Four different sensor resolutions available (1280, 2040, 3070, 4090)
- ✓ High industrial protection class IP67
- ✓ Available with various lens mounts and Scheimpflug adapters
- ✓ Lens protection tubes

KEY FACTS

By Professionals for Professionals

Highest Resolution

- ✓ Profile resolution up to 4096 points/profile
- ✓ Sophisticated 3D laser line detection algorithms for every application (FIR-PEAK, MAX, COG, TRSH)
- ✓ Resolution X: up to 5 μm
- ✓ Resolution Z: up to 0.2 μm

Unique Features

- ✓ GenICam 3.0: support of latest 3D standards
- ✓ MultiPart: parallel output of different features (e.g. range, reflectance, scatter) at maximum profile speed with optimized pixel formats
- ✓ MultiPeak: output of up to four different peaks for even more robust 3D data and for scanning transparent or shiny objects
- ✓ Region search and tracking: automatically finds and tracks the laser line in the detector image

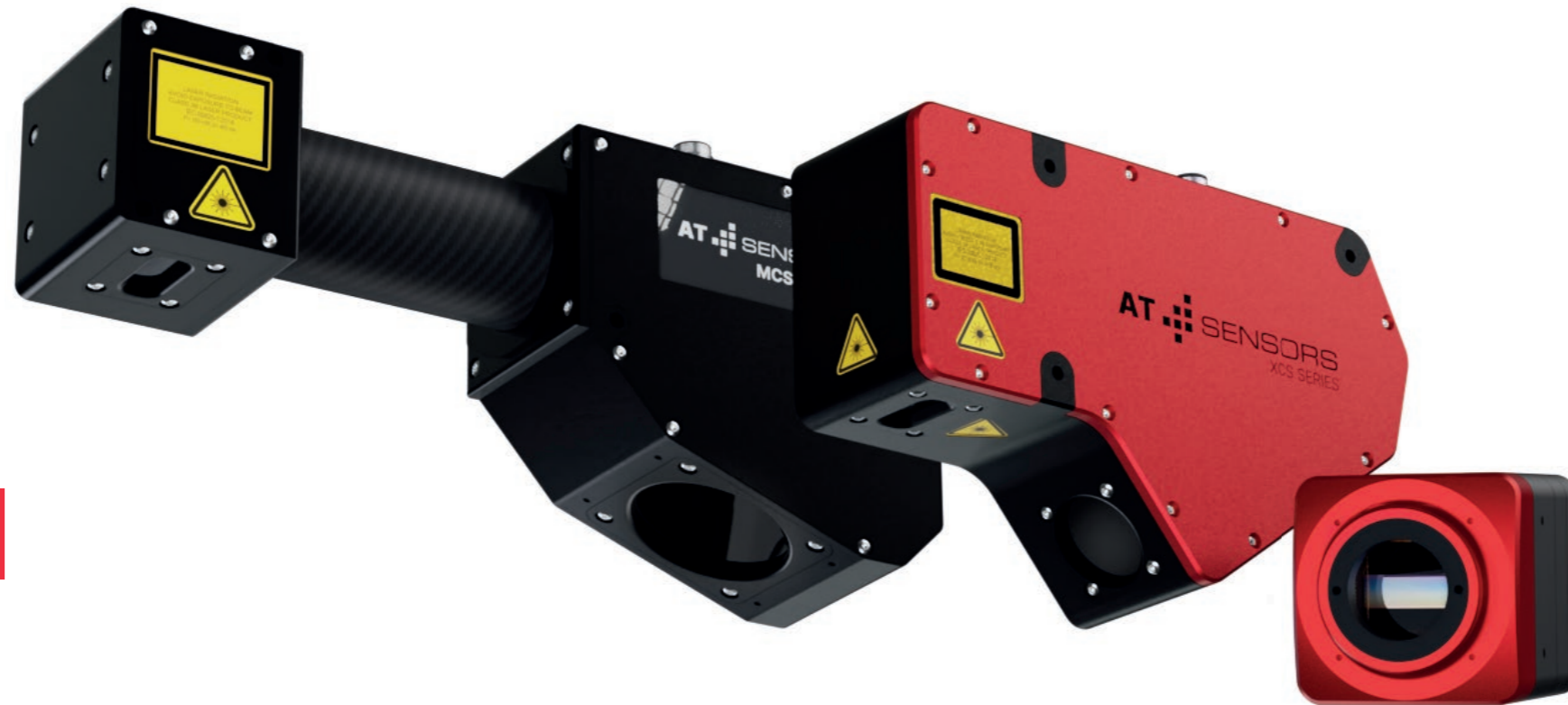

Unmatched Profile Speed

- ✓ Profile speed up to 140 kHz
- ✓ 3D data rate up to 128 million 3D points per second
- ✓ Increase profile speed by defining detector regions
- ✓ Support up to four regions

Various Models

- ✓ Wide range of compact sensors with X-FOV 7 - 1290 mm and numerous laser configurations
- ✓ Wide range of detectors with different resolutions (1280 - 4096 pixel/profile)

Modular Concept

- ✓ Modular Compact Sensors (MCS): individual design optimized for your requirements
- ✓ No additional development costs
- ✓ No minimum order quantity
- ✓ Short delivery time

3070 SENSOR CHIP

World's Fastest 3D Image Sensor

WARP Speed

- ✓ Widely Advanced Rapid Profiling (WARP)
- ✓ Unmatched profile speed
- ✓ Three different speed levels

On-Chip Processing

- ✓ Internal processing speed of 29 gigapixels/s
- ✓ 3D profile pixel output rate of 128 megapixels/s

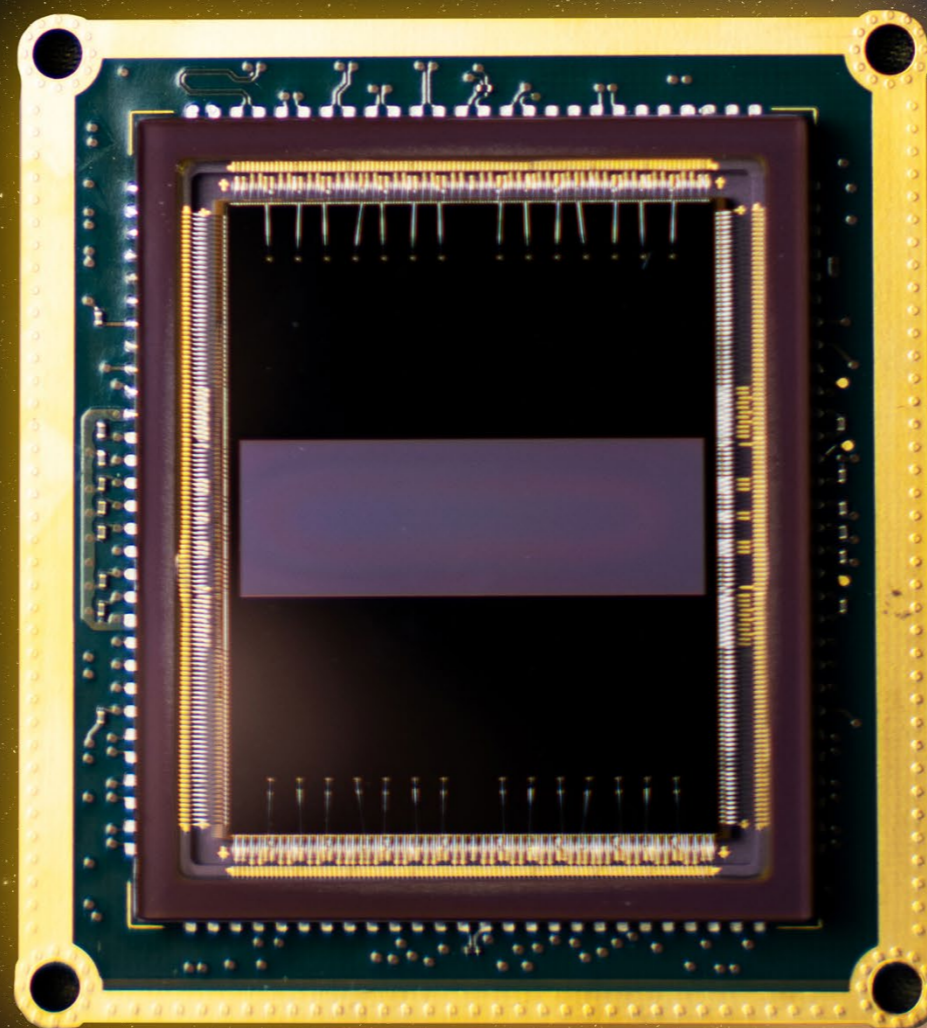

AT's Sensor Technology

- ✓ Exclusive 3K imager design developed by AT
- ✓ High sensitivity and high dynamic range pixel design
- ✓ Integrated on-chip processing

World's Fastest Profiling

- ✓ Worldwide fastest 3D image sensor in the combination of speed and resolution
- ✓ Intelligent line detection algorithms with advanced filtering and validation for highly accurate scans

Ten Times Faster 3D Scans

AT LASER PROFILERS

Overview

ESSENTIAL



CS

- ✓ Large selection of field of views
- ✓ Five different sensor models available

Typical Industries: Automotive, Logistics & Packaging, Wood & Lumber, Pharma, Robotics & Automation, Iron & Steel

BUDGET

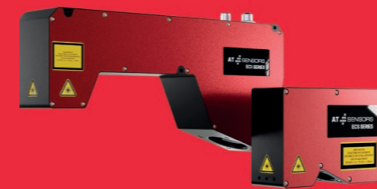

ECS

- ✓ Optimal price-performance ratio
- ✓ Cost-efficient

Typical Industries: Food & Beverage, Logistics & Packaging, Robot Vision

PERFORMANCE

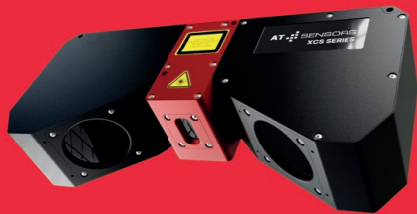

XCS

- ✓ Extremely high resolution
- ✓ High-quality laser line projection
- ✓ No occlusion with dual-head option

Typical Industries: Electronics, Semicon

CUSTOMIZATION



CAMERAS

- ✓ Compatible with custom components
- ✓ Optimal for complex multi-sensor applications
- ✓ Available with different Scheimpflug configurations

Typical Industries: Iron & Steel, Plastics, Electronics, Transportation, Robotics & Automation

FLEXIBILITY



MCS

- ✓ Modular sensor concept for individual solutions
- ✓ No extra costs, short delivery time and no minimum order quantities

Typical Industries: Automotive, Logistics & Packaging, Wood & Lumber, Pharma, Robotics & Automation, Iron & Steel, Plastics, Transportation, Metrology, Sorting & Recycling

COMPACTNESS

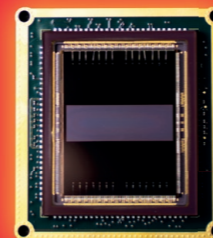

CORES

- ✓ Ideal for integration in OEM devices
- ✓ Different sensor and laser modules available

Typical Industries: OEM specific

APPLICATION VARIETY

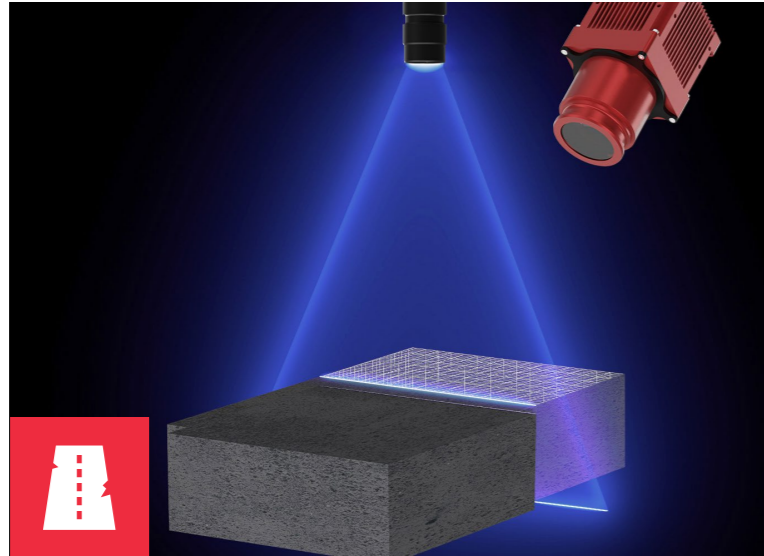

Brick Inspection

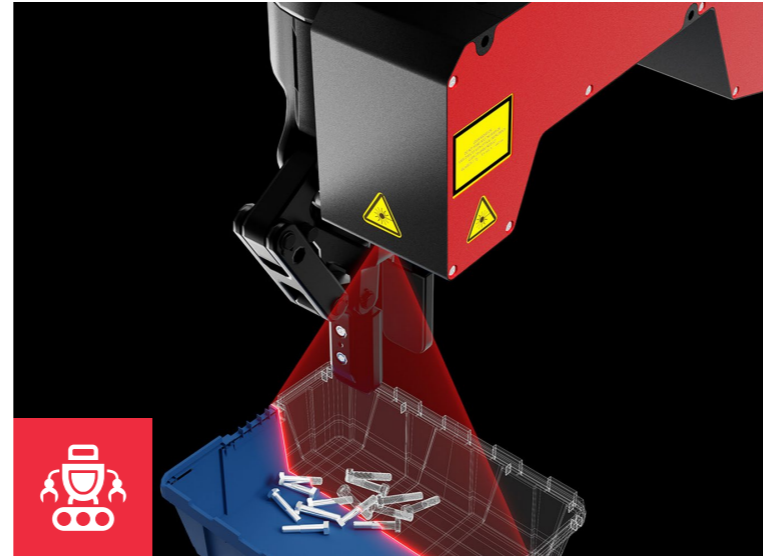

Position Recognition

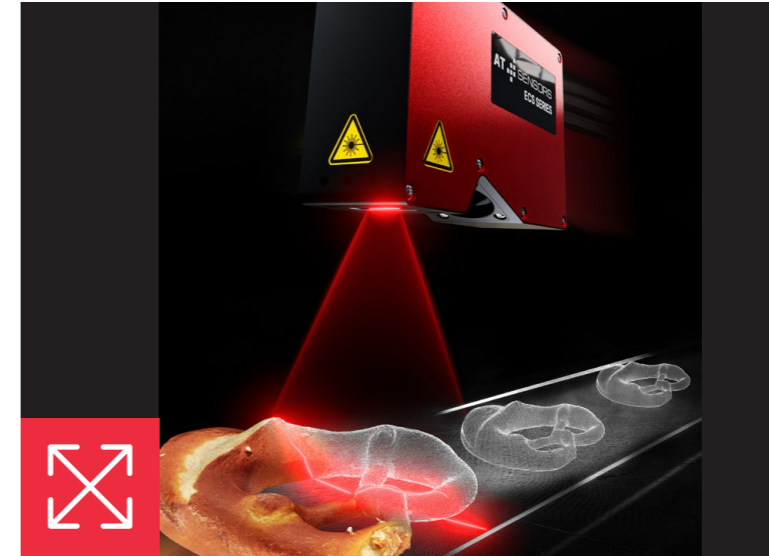

Baking Volume Control

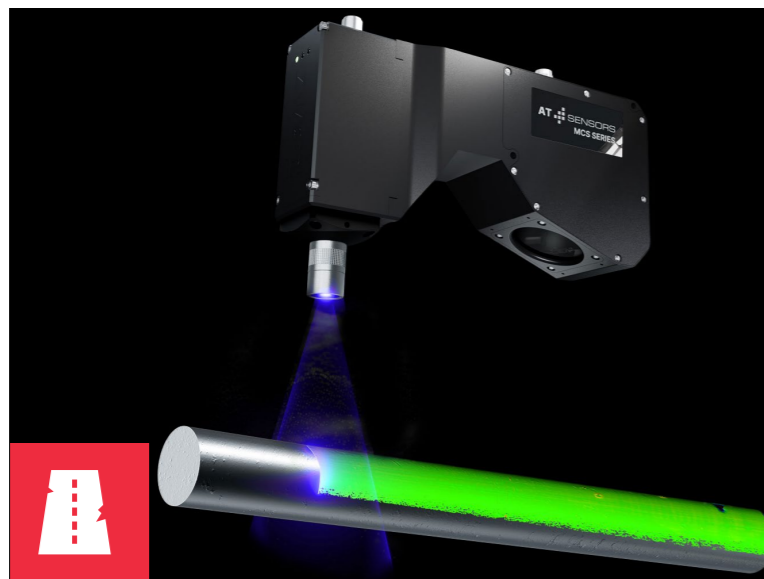

Steel Slab Inspection

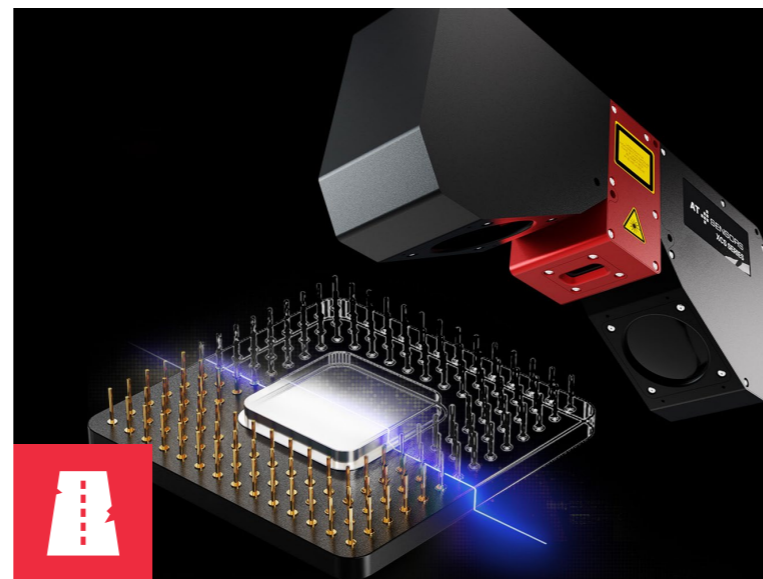

Pin Inspection

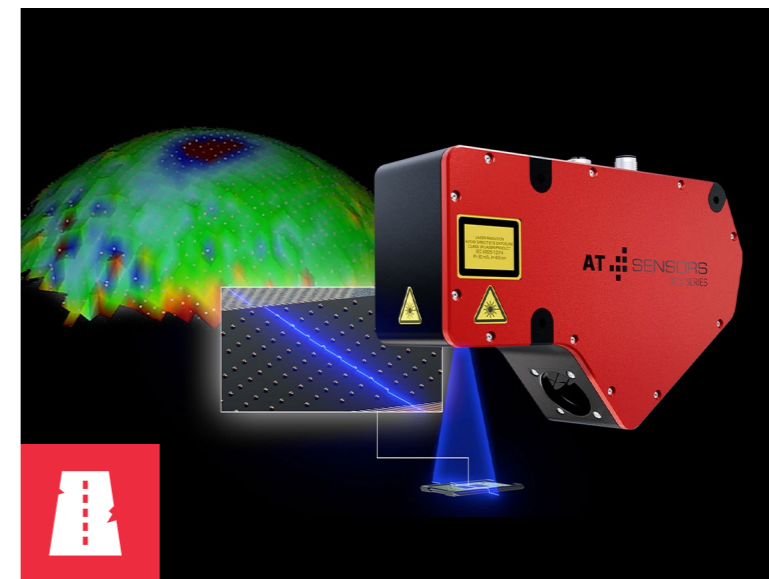

BGA Inspection



Surface
Inspection



Robot
Guidance



Metrology

COMPACT SENSORS



3D Compact Sensor Housing Model G6

- ✓ Profile resolution up to 2048 points / profile
- ✓ Profile speed up to 140 kHz
- ✓ Wide range of models with X-FOV 7 - 53 mm
- ✓ Nominal working distance: 31 - 90 mm
- ✓ Resolution X: 5 - 26 μm
- ✓ Resolution Z: 0.2 - 1.2 μm
- ✓ Z-Range 5 - 46 mm
- ✓ Linearity Z: +/-0.01 % of Z-Range
- ✓ Repeatability Z: 0.1 - 0.5 μm

3D Compact Sensor Housing Model G5

- ✓ Profile resolution up to 4096 points / profile
- ✓ Profile speed up to 25 kHz
- ✓ Wide range of models with X-FOV 82 and 145 mm
- ✓ Nominal working distance: 172 mm
- ✓ Resolution X: 20 - 35 μm
- ✓ Resolution Z: 0.5 - 0.9 μm
- ✓ Z-Range 15 mm
- ✓ Linearity Z: +/-0.01 % of Z-Range
- ✓ Repeatability Z: 0.4 - 0.7 μm

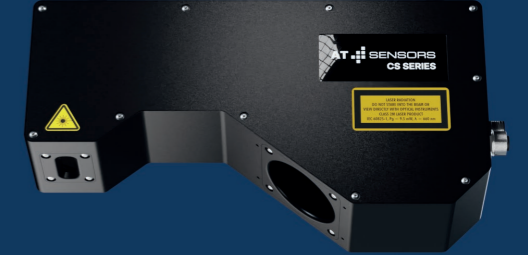

3D Compact Sensor Housing Model G1

- ✓ Profile resolution up to 2048 points / profile
- ✓ Profile speed up to 140 kHz
- ✓ Wide range of models with X-FOV 29 - 160 mm
- ✓ Nominal working distance: 106 - 197 mm
- ✓ Resolution X: 19 - 78 μm
- ✓ Resolution Z: 0.8 - 5.9 μm
- ✓ Z-Range 40 - 80 mm
- ✓ Linearity Z: +/-0.01 % of Z-Range
- ✓ Repeatability Z: 0.4 - 6.6 μm

3D Compact Sensor Housing Model G3

- ✓ Profile resolution up to 4096 points / profile
- ✓ Profile speed up to 140 kHz
- ✓ Wide range of models with X-FOV 182 - 1290 mm
- ✓ Nominal working distance: 400 - 944 mm
- ✓ Resolution X: 44 - 586 μm
- ✓ Resolution Z: 1.4 - 35.3 μm
- ✓ Z-Range 250 - 1090 mm
- ✓ Linearity Z: +/-0.01 % of Z-Range
- ✓ Repeatability Z: 2.1 - 10.0 μm



Good to know:

- ✓ Factory calibrated laser profile sensors
- ✓ Wide range of models with X-FOV 7 - 1290 mm
- ✓ Four different sensor resolutions available (1280, 2040, 3070, 4090)
- ✓ High industrial protection class IP67
- ✓ Available with various laser configurations
- ✓ Resolution Z up to 0.2 μm

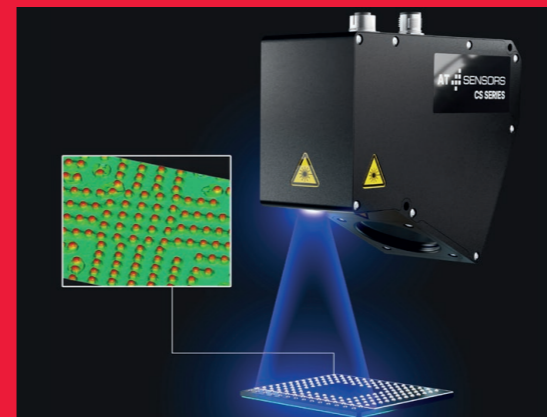

Recommended Applications:

- ✓ Electronics & Semicon
- ✓ eMobility & Battery
- ✓ Automotive
- ✓ Metrology
- ✓ Industrial Automation
- ✓ Transportation
- ✓ Iron & Steel
- ✓ Pharmaceuticals
- ✓ Sorting & Recycling

| Housing Model G6 | | | | | | | | | |
|------------------|------------------|------------------|--------------------------|-------------------|-------------------|--------------------|---------------------|-----------------------|--------------------|
| Model Name | Nominal X-FOV | Z-Range | Nominal Working Distance | Resolution X (μm) | Resolution Z (μm) | Points per Profile | Profile Speed (kHz) | Laser Wavelength (nm) | Laser Safety Class |
| C6-1280CS35-7 | 7 mm (0.27 in) | 5.2 mm (0.20 in) | 31 mm (1.22 in) | 5 | 0.2 | 1280 | 140 | 405, 450 | 2M, 3R, 3B |
| C6-1280CS35-12 | 12 mm (0.47 in) | 8 mm (0.31 in) | 31 mm (1.22 in) | 10 | 0.2 | 1280 | 140 | 405, 450 | 2M, 3R, 3B |
| C6-1280CS25-20 | 20 mm (0.78 in) | 20 mm (0.78 in) | 72 mm (2.83 in) | 16 | 0.5 | 1280 | 140 | 405, 450 | 2M, 3R, 3B |
| C6-1280CS21-40 | 40 mm (1.57 in) | 46 mm (1.81 in) | 90 mm (3.54 in) | 31 | 1.2 | 1280 | 140 | 405 | 2M, 3R, 3B |
| C6-2040CS21-53 | 53 mm (2.08 in) | 46mm (1.81 in) | 90 mm (3.54 in) | 26 | 1 | 2048 | 25 | 405 | 2M, 3R, 3B |

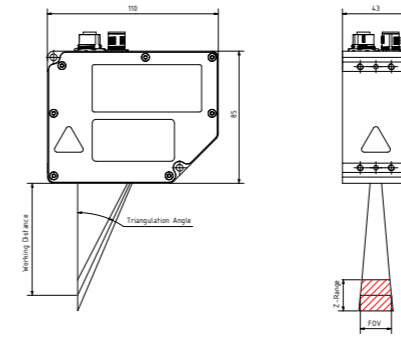

Housing Model G6

| Housing Model G1 | | | | | | | | | |
|------------------|------------------|------------------|--------------------------|-------------------|-------------------|--------------------|---------------------|-----------------------|--------------------|
| Model Name | Nominal X-FOV | Z-Range | Nominal Working Distance | Resolution X (μm) | Resolution Z (μm) | Points per Profile | Profile Speed (kHz) | Laser Wavelength (nm) | Laser Safety Class |
| C6-1280CS23-29 | 29 mm (1.14 in) | 40 mm (1.57 in) | 106 mm (4.17 in) | 23 | 0.8 | 1280 | 140 | 405, 660 | 2M, 3R, 3B |
| C6-2040CS23-38 | 38 mm (1.49 in) | 30 mm (1.18 in) | 106 mm (4.17 in) | 19 | 0.7 | 2048 | 25 | 405, 660 | 2M, 3R, 3B |
| C6-1280CS23-47 | 47 mm (1.85 in) | 40 mm (1.57 in) | 106 mm (4.17 in) | 37 | 1.4 | 1280 | 140 | 405, 660 | 2M, 3R, 3B |
| C6-2040CS23-63 | 63 mm (2.48 in) | 40 mm (1.57 in) | 106 mm (4.17 in) | 31 | 1.2 | 2048 | 25 | 405, 660 | 2M, 3R, 3B |
| C6-1280CS23-75 | 75 mm (2.95 in) | 40 mm (1.57 in) | 106 mm (4.17 in) | 59 | 2.3 | 1280 | 140 | 405, 660 | 2M, 3R, 3B |
| C6-1280CS14-76 | 76 mm (2.99 in) | 80 mm (3.14 in) | 197 mm (7.75 in) | 59 | 3.5 | 1280 | 140 | 405, 660 | 2M, 3R, 3B |
| C6-2040CS14-100 | 100 mm (3.93 in) | 120 mm (4.72 in) | 197 mm (7.75 in) | 49 | 2.9 | 2048 | 25 | 405, 660 | 2M, 3R, 3B |
| C6-2040CS23-100 | 100 mm (3.93 in) | 60 mm (2.36 in) | 106 mm (4.17 in) | 49 | 1.9 | 2048 | 25 | 405, 660 | 2M, 3R, 3B |
| C6-1280CS14-120 | 120 mm (4.72 in) | 120 mm (4.72 in) | 197 mm (7.75 in) | 94 | 5.9 | 1280 | 140 | 405, 660 | 2M, 3R, 3B |
| C6-2040CS14-160 | 160 mm (6.29 in) | 80 mm (3.14 in) | 197 mm (7.75 in) | 78 | 4.9 | 2048 | 25 | 405, 660 | 2M, 3R, 3B |

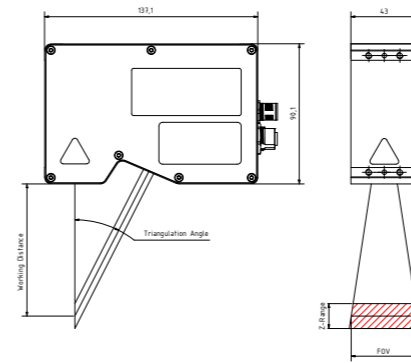

Housing Model G1

| Housing Model G5 | | | | | | | | | |
|------------------|------------------|-----------------|--------------------------|-------------------|-------------------|--------------------|---------------------|-----------------------|--------------------|
| Model Name | Nominal X-FOV | Z-Range | Nominal Working Distance | Resolution X (μm) | Resolution Z (μm) | Points per Profile | Profile Speed (kHz) | Laser Wavelength (nm) | Laser Safety Class |
| C6-4090CS39-82 | 82 mm (3.22 in) | 15 mm (0.59 in) | 172 mm (6.77 in) | 20 | 0.5 | 4096 | 20 | 405, 660 | 2M, 3R, 3B |
| C6-4090CS39-145 | 145 mm (5.70 in) | 15 mm (0.59 in) | 172 mm (6.77 in) | 35 | 0.9 | 4096 | 20 | 405, 660 | 2M, 3R, 3B |

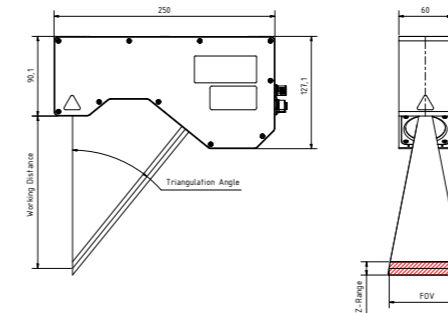

Housing Model G5

| Housing Model G3 | | | | | | | | | |
|------------------|--------------------|--------------------|--------------------------|-------------------|-------------------|--------------------|---------------------|-----------------------|--------------------|
| Model Name | Nominal X-FOV | Z-Range | Nominal Working Distance | Resolution X (μm) | Resolution Z (μm) | Points per Profile | Profile Speed (kHz) | Laser Wavelength (nm) | Laser Safety Class |
| C6-4090CS30-182 | 182 mm (7.16 in) | 150 mm (6.25 in) | 400 mm (15.74 in) | 44 | 1.4 | 4096 | 25 | 405, 660 | 2M, 3R, 3B |
| C6-1280CS30-248 | 248 mm (9.76 in) | 200 mm (7.87 in) | 400 mm (15.74 in) | 194 | 6.1 | 1280 | 140 | 405, 660 | 2M, 3R, 3B |
| C6-4090CS30-288 | 288 mm (11.33 in) | 250 mm (9.84 in) | 400 mm (15.74 in) | 70 | 2.2 | 4096 | 25 | 405, 660 | 2M, 3R, 3B |
| C6-2040CS30-330 | 330 mm (12.99 in) | 200 mm (7.87 in) | 400 mm (15.74 in) | 161 | 5.0 | 2048 | 25 | 405, 660 | 2M, 3R, 3B |
| C6-2040CS18-1060 | 1060 mm (41.73 in) | 800 mm (31.49 in) | 744 mm (29.29 in) | 518 | 26.2 | 2048 | 25 | 405, 660 | 2M, 3R, 3B |
| C6-2040CS15-1290 | 1290 mm (50.78 in) | 1090 mm (42.91 in) | 920 mm (36.22 in) | 630 | 38.0 | 2048 | 25 | 405, 660 | 2M, 3R, 3B |

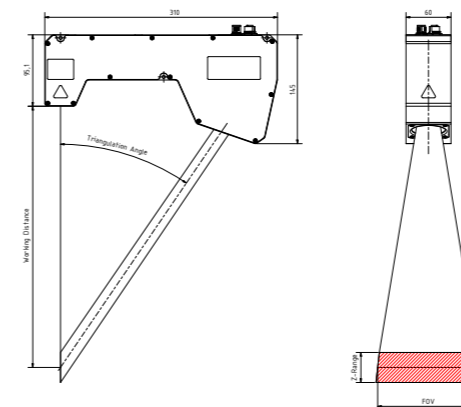

Housing Model G3

MODULAR COMPACT SENSOR

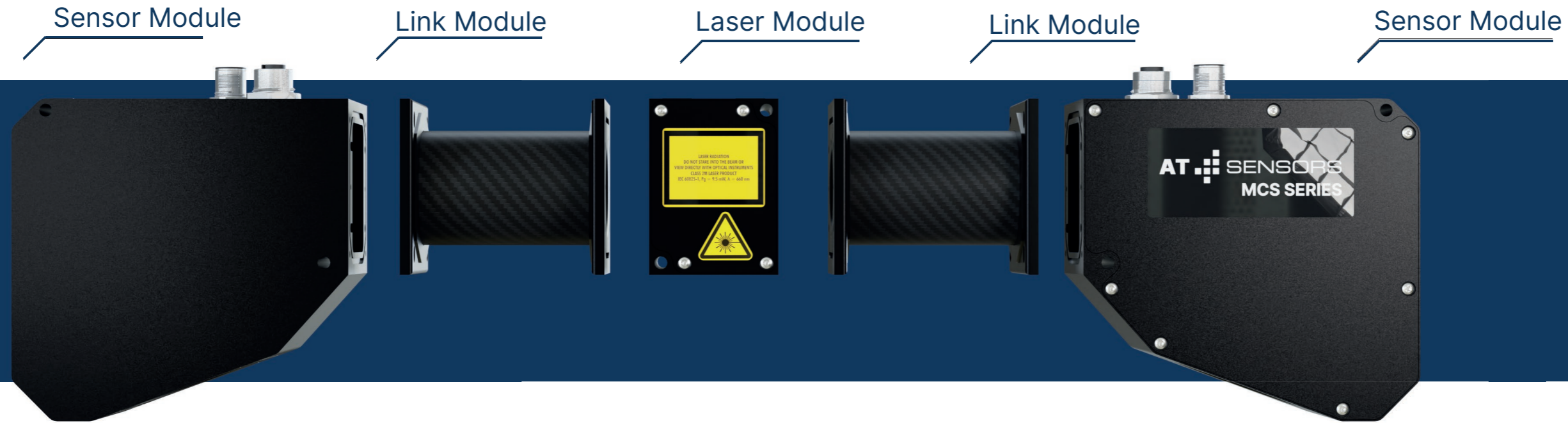

Configurable according to application requirements:

- ✓ X-FOV
- ✓ Working distance
- ✓ Triangulation angle
- ✓ Number of points per profile
- ✓ Laser wavelength
- ✓ Laser safety class

Sensor Specification

| | |
|-----------------------------|---|
| X-FOV at Working Distance | > 2000 mm |
| Lateral X Resolution | down to 50 μm |
| Nominal Working Distance | > 1700 mm |
| Nominal Triangulation Angle | 15°, 20°, 25°, 30°, 40° |
| Profile Resolution | 1280, 2040, 3072, 4096 points per profile |
| Profile Speed | up to 140 kHz |
| Available Sensor Modules | 1280, 2040, 3070, 3070W (WARP), 4090 |

Laser Specification

| | |
|------------------|--------------|
| Laser Wavelength | 405, 660 nm |
| Laser Power | up to 200 mW |
| Laser Class | 2M, 3R, 3B |

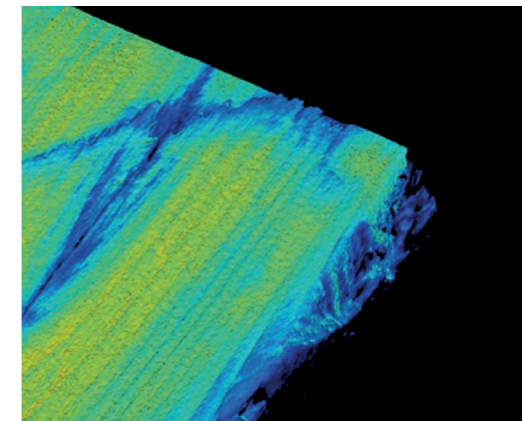

Good to know:

- ✓ Factory assembled and calibrated 3D laser profile sensors consisting of sensor module, laser module and link module
- ✓ Customized laser profile sensor designs without NRE or MOQ
- ✓ Four different sensor resolutions available (1280, 2040, 3070, 4090)
- ✓ Configurable according to application requirements like X-FOV, working distance, triangulation angle, number of points per profile, laser wavelength and laser safety class
- ✓ Dual-head configuration possible for occlusion-free 3D scans
- ✓ High industrial protection class IP67



Recommended Applications:

- ✓ Electronics & Semicon
- ✓ eMobility & Battery
- ✓ Automotive
- ✓ Metrology
- ✓ Industrial Automation
- ✓ Transportation
- ✓ Iron & Steel
- ✓ Pharmaceuticals
- ✓ Sorting & Recycling

MCS

with High-Power Laser

Different Configurations available



AT Sensors has expanded the range of its modular sensor series (MCS). This now includes a powerful high-performance laser module, which has been developed primarily for demanding applications in the iron & steel industry as well as for infrastructure inspection and road scanning.

Comparison Laser Modules

| | MCS Standard | MCS High Power Laser |
|------------------|--------------|----------------------|
| Laser Wavelength | 405, 660 nm | 450, 760, 808 nm |
| Laser Power | up to 200 mW | up to 2500 mW |
| Laser Class | 2M, 3R, 3B | 3B |

Benefits:

- Higher laser power (10x more output power compared to standard)
- Faster scan rates in demanding environmental conditions like difficult lighting such as bright ambient light
- For applications where high speed or a large working distance is required

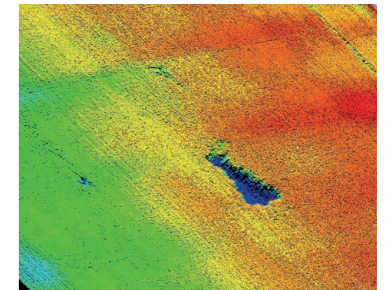
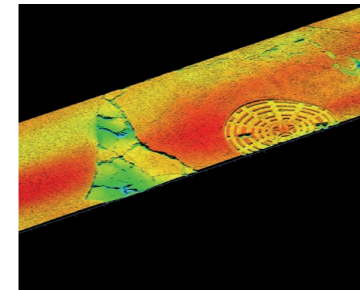

Good to know:

- ✓ based on AT's unique modular 3D laser profile sensor concept
- ✓ World's fastest 3D profiling
- ✓ Intelligent data compression directly on the sensor chip
- ✓ Up to ten times faster 3D scans
- ✓ Profile speed up to 140 kHz
- ✓ High laser power through laser class 3R/3B
- ✓ Large field of view of up to 2800 mm



Recommended Applications:

- ✓ Road pavement scanning
- ✓ Inspection of cold or red-hot steel parts
- ✓ Scanning of railroad infrastructure

XCS SERIES

with 1 Gigabit/s

Available Models:

3070 WARP:

- ✓ 602344999 / C6-3070W-XCS-48-146-D-405-3R
- ✓ 602345000 / C6-3070W-XCS-48-146-S-405-3R

3070:

- ✓ 602345001 / C6-3070-XCS-48-146-D-405-3R
- ✓ 602345002 / C6-3070-XCS-48-146-S-405-3R

4090:

- ✓ 602344997 / C6-4090-XCS-53-146-D-405-3R
- ✓ 602344998 / C6-4090-XCS-53-146-S-405-3R

Benefits:

- Higher laser power (10x more output power compared to standard)
- Faster scan rates in demanding environmental conditions like difficult lighting such as bright ambient light
- For applications where high speed or a large working distance is required

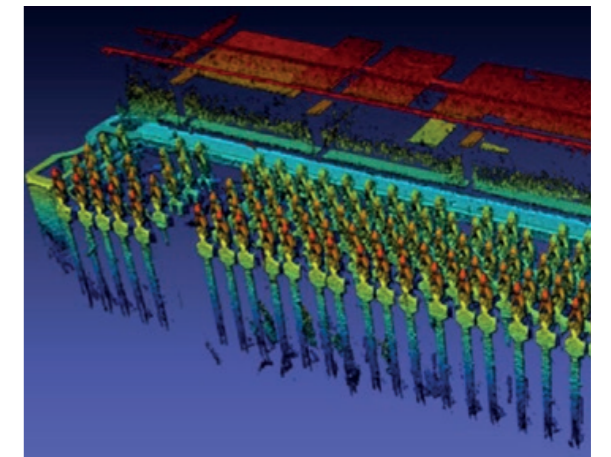
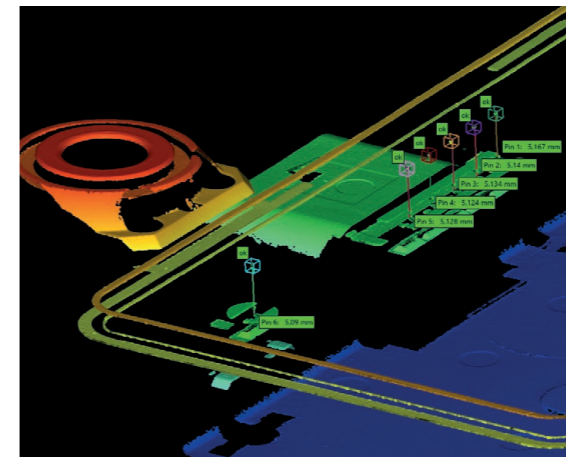

Good to know:

- ✓ Unique 3D scan results without occlusion due to dual-head option and extremely high profile speed at 3072 or 4096 points per profile
- ✓ High precision and repeatability thanks to high-quality laser line projection
- ✓ Unrivaled optical resolution for electronic inspection (e.g. BGA inspection) with a field of view of up to 53 mm
- ✓ Highest inspection speed available with 3070 WARP sensor chip

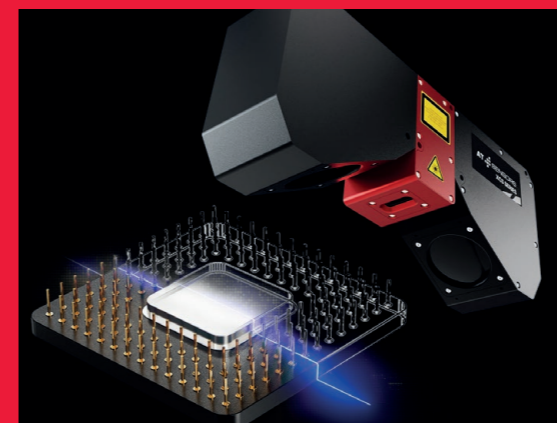

Recommended Applications:

- ✓ Electronics & Semicon
- ✓ E-Mobility & Battery
- ✓ Automotive Metrology
- ✓ Industrial Automation
- ✓ Welding
- ✓ Pharmaceuticals
- ✓ Wood & Lumber

General Specifications for all XCS Models

| | |
|--------------------------|---|
| Interface | Gigabit Ethernet (1GigE) |
| Inputs | Encoder A+, A -, B+, B -, Z+, Z- (TTL Level) Two freely configurable digital inputs (+5 to +24 VDC) |
| Outputs | Two freely configurable digital outputs (+5 to +24 VDC) |
| Power Supply | Sensor supply +10 to +24 VDC (max. +27 VDC) Laser supply +10 to +24 VDC |
| Housing | Anodized aluminum, IP67 |
| Environmental Conditions | Operating temperature 0 °C to +40 °C Storage temperature -20 °C to +80 °C Humidity 20% to 80% |
| Vibration/Shock | Vibration resistance (sinusoidal): DIN EN 60068-2-6: 2008-10: 2g, 10-150 Hz Vibration resistance (random): DIN EN 60068-2-64: 2020-09: 7g, 10-500 Hz Shock resistance: DIN EN 60068-2-27: 2010-02: 15g, 3ms |
| Communication Protocols | GenICam, GigE Vision |
| Features | Automatic RegionTracking, Automatic RegionSearch, Multiple Regions, MultiPart, AutoStart, History Buffer, Multi-Slope, MultiPeak |

Laser Specifications for all XCS Models

| | |
|------------------|--------|
| Laser Wavelength | 405 nm |
| Laser Class | 3R |

Models 3070 / 3070 WARP

| | |
|--------------------------|--|
| Part Number / Model Name | 602344999 / C6-3070W-XCS-48-146-D-405-3R 602345000 / C6-3070W-XCS-48-146-S-405-3R 602345001 / C6-3070-XCS-48-146-D-405-3R 602345002 / C6-3070-XCS-48-146-S-405-3R |
|--------------------------|--|

Optical Setup 3070 / 3070 WARP

| | |
|----------------------|---------------------------------------|
| Lateral Resolution X | 0.016 mm |
| Height Resolution Z | 0.5 µm (with 6 subpixels) |
| Working Distance | 146 mm |
| X-FOV | 48 mm |
| Profile Resolution | 3072 pixel per profile |
| Profile Speed | max. 140 kHz, 14.5 kHz @ full Z-Range |
| Z-Range Near to Far | 20 mm |

Models 4090

| | |
|--------------------------|--|
| Part Number / Model Name | 602344997 / C6-4090-XCS-53-146-D-405-3R 602344998 / C6-4090-XCS-53-146-S-405-3R |
|--------------------------|--|

Optical Setup 4090

| | |
|----------------------|----------------------------|
| Lateral Resolution X | 0.013 mm |
| Height Resolution Z | 0.42 µm (with 6 subpixels) |
| Working Distance | 146 mm |
| X-FOV | 53 mm |
| Profile Resolution | 4096 pixel per profile |
| Profile Speed | max. 20.3 kHz |
| Z-Range Near to Far | 10 mm |

Technical Drawings Dual-Head

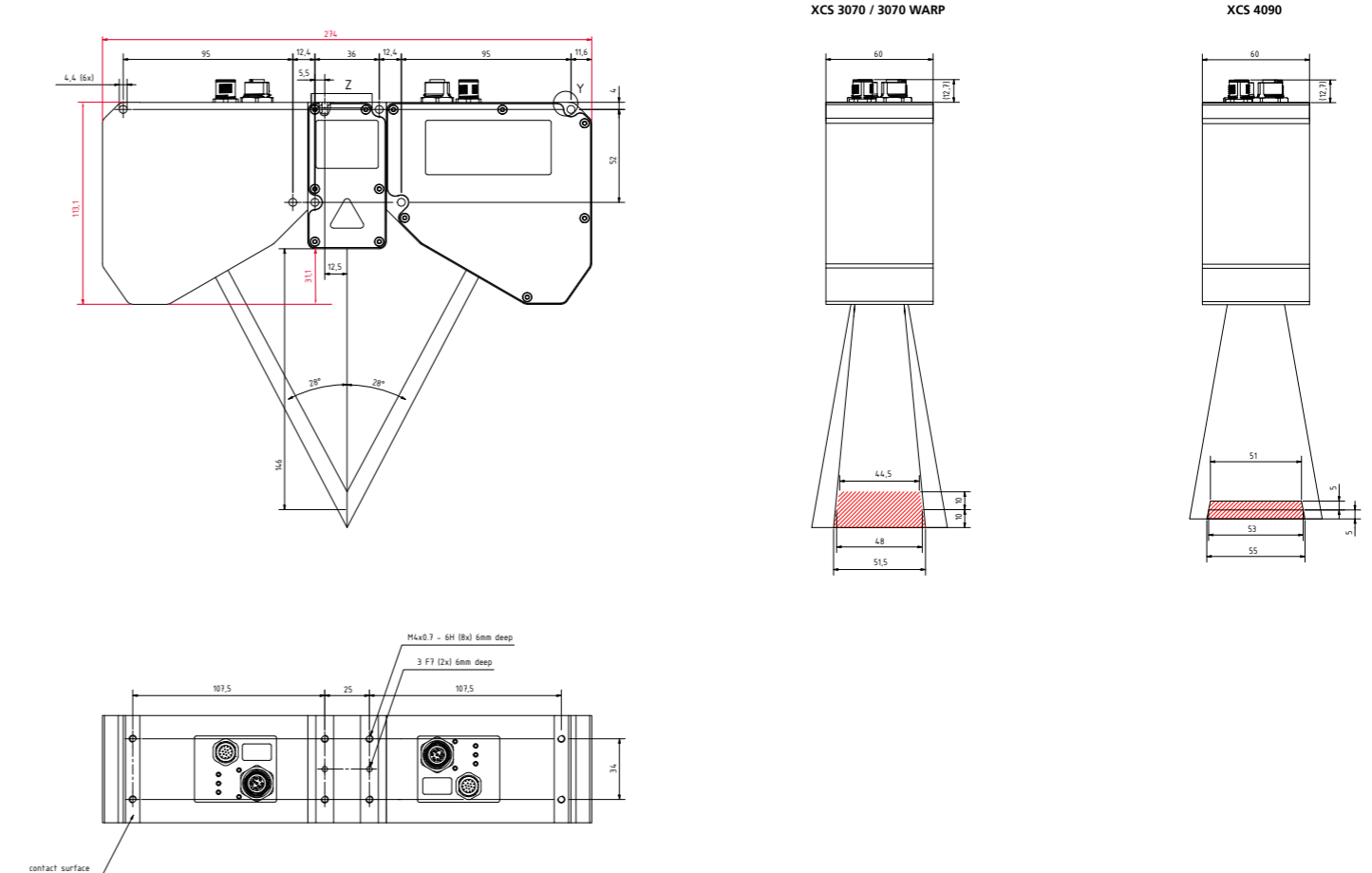

Technical Drawings Single-Head

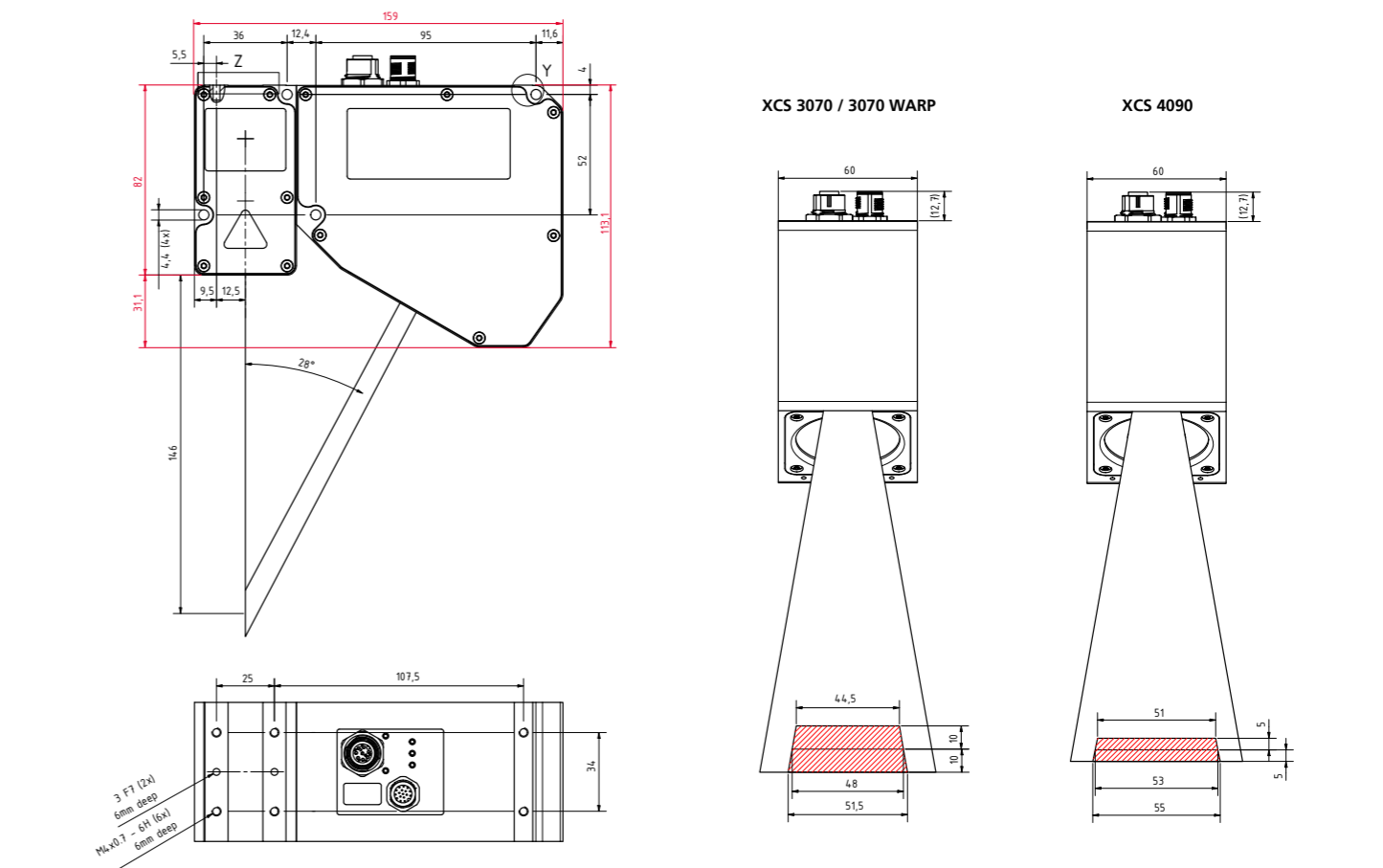

XCS SERIES

with 5 Gigabit/s

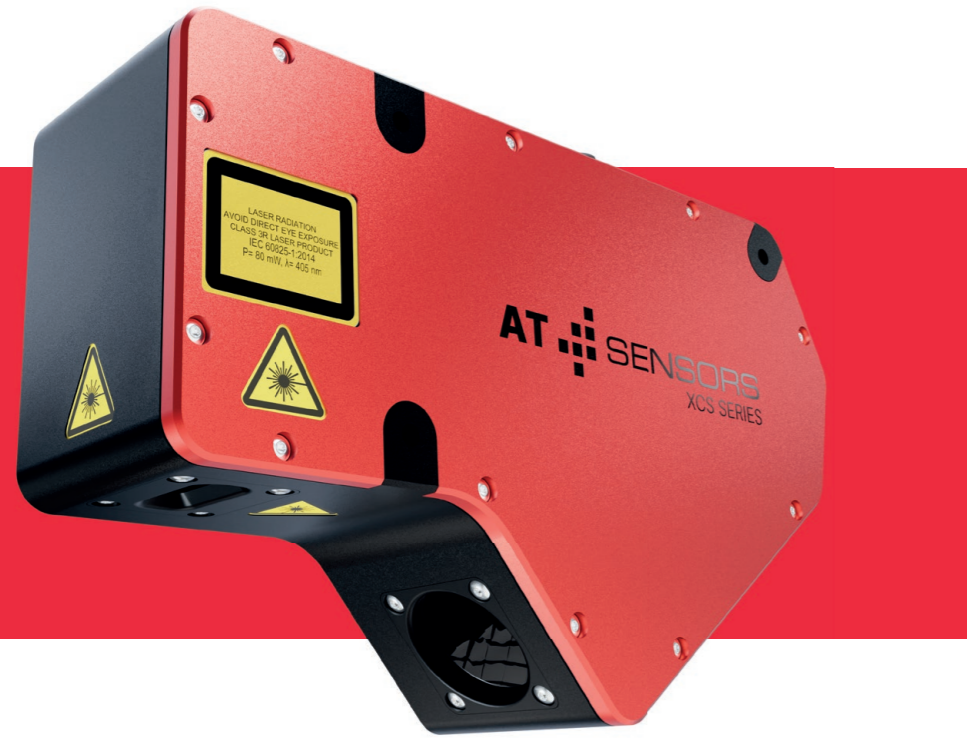

Available Models:

3070 WARP:

- ✓ C7-S8-3070W-XCS-50-24-85-SX-5G-405-3R
- ✓ C7-S8-3070W-XCS-28-48-146-SX-5G-405-3R
- ✓ C7-S8-3070W-XCS-28-48-146-DX-5G-405-3R

3070:

- ✓ C7-S8-3070-XCS-50-24-85-SX-5G-405-3R
- ✓ C7-S8-3070-XCS-28-48-146-SX-5G-405-3R
- ✓ C7-S8-3070-XCS-28-48-146-DX-5G-405-3R

Benefits:

- Fills the gap in high-resolution (lateral X-resolution) sensors that we were previously unable to serve
- High-precision, ultra-thin laser line, 405 nm, 3R
- Developed for highly demanding inline inspection applications with high data transfer requirements



Good to know:

- ✓ Our first compact sensor with 5 GBit/s Interface
- ✓ Available with 3070 and 3070 WARP
- ✓ Newly designed housing
- ✓ Simultaneous data transfer of multiple features

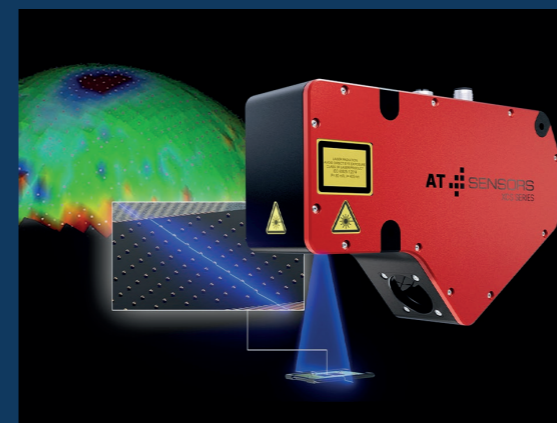

Recommended Applications:

- ✓ Advanced Packaging
- ✓ Semiconductor
- ✓ Electronics

General Specifications for all XCS Models with 5G

| | |
|--------------------------|---|
| Interface | Ethernet 100 Mb, 1 Gb, 2.5 Gb, 5 Gb |
| Inputs | Encoder A+, A -, B+, B -, Z+, Z- (HTL/TTL Level supported) Two freely configurable digital inputs (+5 to +24 VDC) |
| Outputs | Two freely configurable digital outputs (+5 to +24 VDC) |
| Power Supply | Sensor supply +10 to +24 VDC (max. +27 VDC) Laser supply +10 to +24 VDC |
| Housing | Anodized aluminum, IP67 |
| Environmental Conditions | Operating temperature 0 °C to +40 °C Storage temperature -20 °C to +80 °C Humidity 20% to 80% |
| Vibration/Shock | Vibration resistance (sinusoidal): DIN EN 60068-2-6: 2008-10: 2g, 10-150 Hz Vibration resistance (random): DIN EN 60068-2-64: 2020-09: 7g, 10-500 Hz Shock resistance: DIN EN 60068-2-27: 2010-02: 15g, 3ms |
| Communication Protocols | GenICam, GigE Vision |
| Features | Automatic RegionTracking, Automatic RegionSearch, Multiple Regions, MultiPart, AutoStart, History Buffer, Multi-Slope, MultiPeak |

Laser Specifications

| | |
|------------------|--------|
| Laser Wavelength | 405 nm |
| Laser Class | 3R |

Models 3070 / 3070 WARP

| | |
|--------------------------|---|
| Part Number / Model Name | 602345872 / C7-S8-3070-XCS-50-24-85-SX-5G-405-3R 602346067 / C7-S8-3070W-XCS-50-24-85-SX-5G-405-3R 602346173 / C7-S8-3070W-XCS-28-48-146-SX-5G-405-3R 602346174 / C7-S8-3070W-XCS-28-48-146-DX-5G-405-3R 602346199 / C7-S8-3070-XCS-28-48-146-SX-5G-405-3R 602346200 / C7-S8-3070-XCS-28-48-146-DX-5G-405-3R |
|--------------------------|---|

Optical Setup 3070 / 3070 WARP

| Model | X-FOV 24 mm | X-FOV 48 mm |
|----------------------|----------------------------|------------------------|
| Lateral Resolution X | 7.8 µm | 15.6 µm |
| Height Resolution Z | 0.13 µm (with 6 subpixels) | 0.53 µm |
| Working Distance | 84.5 mm | 146 mm |
| X-FOV | 24 mm | 48 mm |
| Profile Resolution | 3072 pixel per profile | 3072 pixel per profile |
| Profile Speed | max. 94 kHz | max. 94 kHz |
| Z-Range Near to Far | 6 mm | 20 mm |

Technical Drawings Model with X-FOV 24 mm

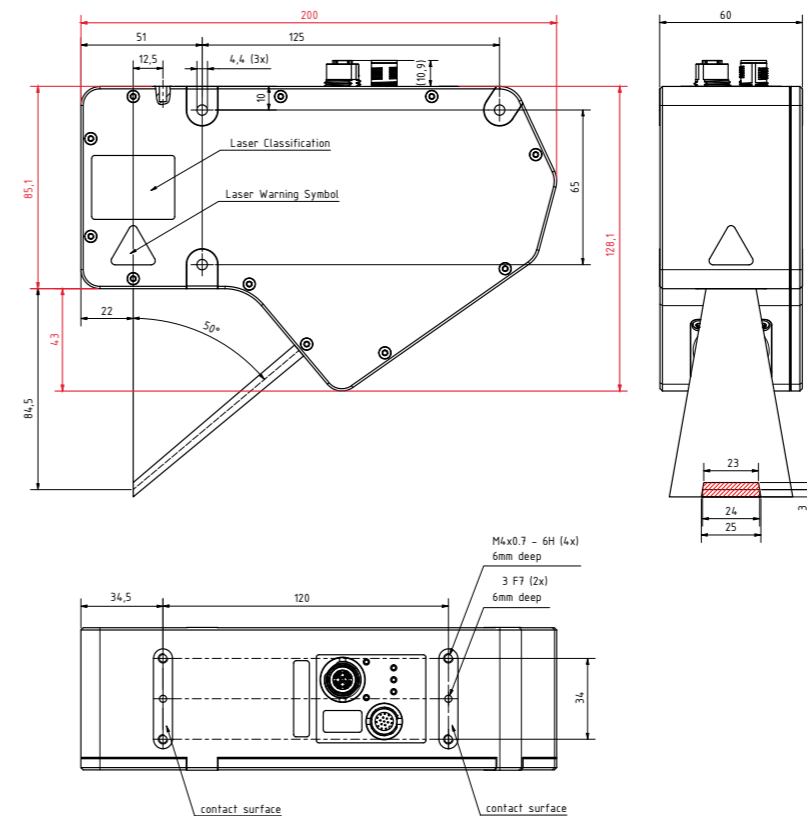

Technical Drawings Model with X-FOV 48 mm

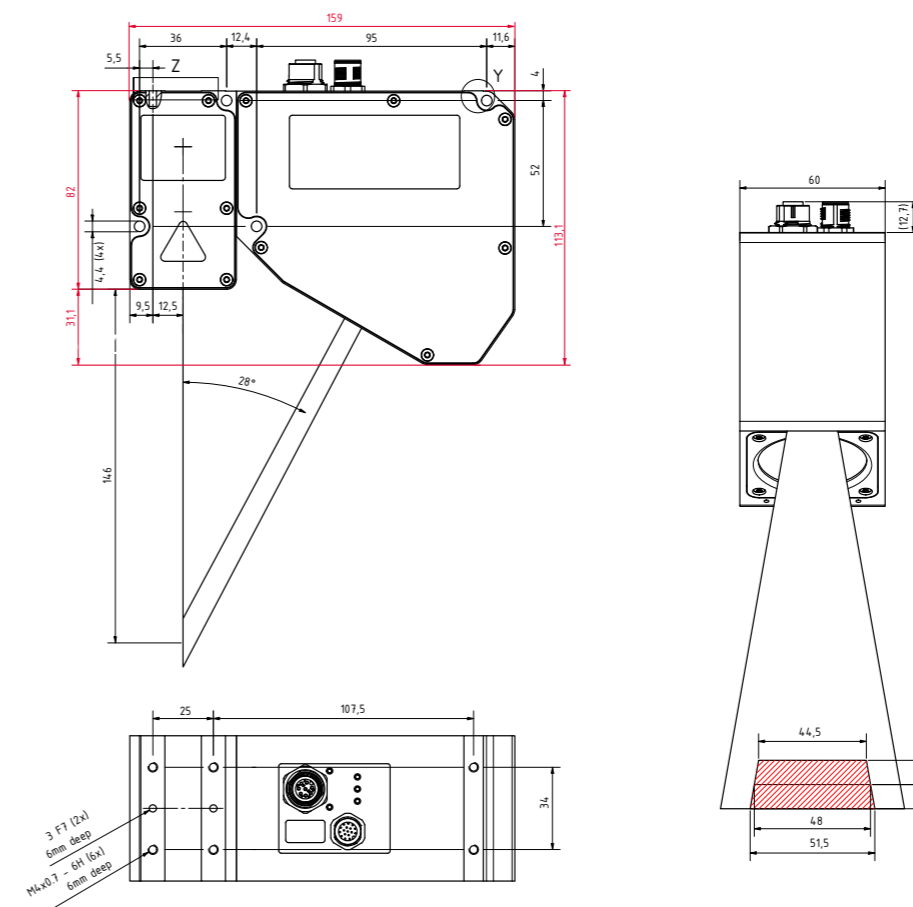

ECS SERIES



ECS 2040

ECS 4090

Technical Drawings

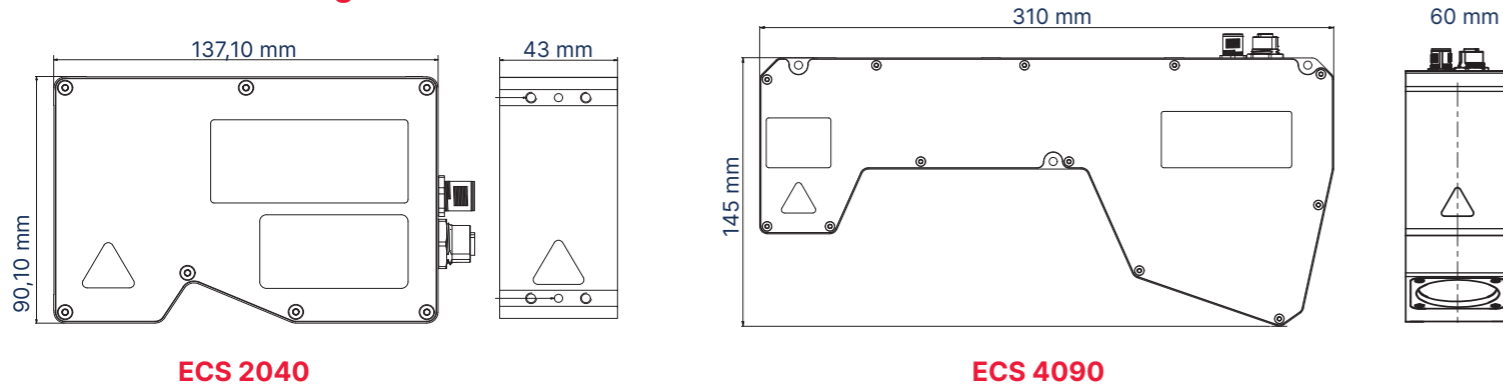

ECS 2040

ECS 4090

Technical Data

| | |
|--------------------------|---|
| Laser Wavelength | 660 nm |
| Laser Safety Class IEC | 2M |
| Interface | Gigabit-Ethernet |
| Inputs | <ul style="list-style-type: none"> Encoder A+, A -, B+, B -, Z+, Z- (TTL Level) Two freely configurable digital inputs (+5 to +24 VDC) |
| Outputs | Two freely configurable digital outputs (+5 to +24 VDC) |
| Power Supply | <ul style="list-style-type: none"> Sensor supply +10 to +24 VDC (max. +27 VDC) Laser supply +10 to +24 VDC |
| Housing | Anodized aluminum , IP54 |
| Environmental Conditions | <ul style="list-style-type: none"> Operating temperature 0 ° C to +40 ° C Storage temperature 20 ° C to +80 ° C Humidity 20 % to 80 % |
| Vibration/Shock | <ul style="list-style-type: none"> Vibration resistance (sinusoidal): DIN EN 60068-2-6: 2008-10: 2 g, 10-150 Hz Vibration resistance (random): DIN EN 60068-2-64: 2020-09: 7 g, 10-500 Hz Shock resistance: DIN EN 60068-2 27: 2010 02: 15 g, 3 ms |
| Standards | GenICam, GigE Vision |
| Features | Automatic Region-Tracking, Automatic Region-Search, Multiple Regions, Multi-Part, AutoStart, History Buffer, Multi-Slope, MultiPeak |

Models

| Model Name | Points | Working Distance (mm) | X-FOV (mm) | Z-Range (mm) | Resolution X Nominal (µm) | Resolution Z (µm) | Profile Speed at 200 rows | Max. Profile Speed |
|---|--------|-----------------------|------------|--------------|---------------------------|-------------------|---------------------------|--------------------|
| C6-S7-2040-ECS-23-100-106-SX-1G-660-2M | 2048 | 106 | 102 | 60 | 49 | 1.9 | 1.8 kHz | 25 kHz |
| C6-S7-2040-ECS-14-160-197-SX-1G-660-2M | 2048 | 197 | 162 | 120 | 78 | 4.9 | 1.8 kHz | 25 kHz |
| C6-S7-4090-ECS-30-288-400-SX-1G-660-2M | 4096 | 400 | 284 | 250 | 71 | 2.1 | 2 kHz | 24 kHz |
| C6-S7-4090-ECS-18-575-740-SX-1G-660-2M | 4096 | 744 | 576 | 500 | 140 | 7.0 | 2 kHz | 24 kHz |
| C6-S7-4090-ECS-18-1020-740-SX-1G-660-2M | 4096 | 744 | 1020 | 900 | 249 | 12.5 | 2 kHz | 24 kHz |

Good to know:

- ✓ Price-performance ratio: Cost-effective laser profile sensor for demanding applications
- ✓ Software standards for easy integration: GigE Vision, GenICam, and third-party software support
- ✓ Cross-industry application: Ideal for the food industry, logistics, and robot vision



Recommended Applications:

- ✓ Food & Beverage
- ✓ Logistics & Packaging
- ✓ Robot Vision

C6 CA CAMERA

Designed for flexible laser triangulation set-ups with user-defined lasers and lenses.

Available Models:

- ✓ C6-S7-1280-CA-S0-M-1G: 1280 x 1024 pixels
- ✓ C6-S7-2040-CA-S0-M-1G: 2048 x 1088 pixels
- ✓ C6-S7-3070-CA-S0-M-1G: 3072 x 1020 pixels
- ✓ C6-S7-3070W-CA-S0-M-1G: 3072 x 1020 pixels with WARP
- ✓ C6-S7-4090-CA-S0-M-1G: 4096 x 3072 pixels

Standard Lens Mount Version with M42x1

Version with Optional C-Mount Adapter



Good to know:

- ✓ Designed for flexible laser triangulation set-ups with user-defined lasers and lenses
- ✓ Four different sensor resolutions available (1280, 2040, 3070, 4090)
- ✓ High industrial protection class IP67
- ✓ Available with various lens mounts and Scheimpflug adapters
- ✓ Lens protection tubes

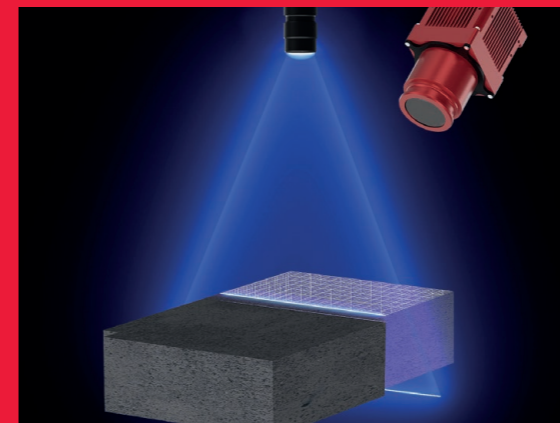

Recommended Applications:

- ✓ Electronics & Semicon
- ✓ eMobility & Battery
- ✓ Automotive
- ✓ Metrology
- ✓ Industrial Automation
- ✓ Transportation
- ✓ Iron & Steel
- ✓ Pharmaceuticals
- ✓ Sorting & Recycling

| Model Name | C6-1280-GigE | | | C6-2040-GigE | | C6-3070-GigE / C6-3070-WARP-GigE | | | C6-4090-GigE | |
|---|--------------------------|----------------------|-------------------|--------------------------|---|---|-------------------|-------------|---|------|
| Sensor Resolution | 1280 × 1024 | | | 2048 × 1088 | | 3072 × 1020 | | | 4096 × 3072 | |
| Pixel Size | 6.6 μm x 6.6 μm | | | 5.5 μm x 5.5 μm | | 6.6 μm x 6.6 μm | | | 5.5 μm x 5.5 μm | |
| Dynamic Range (*with HDR-3D) | 90 dB | | | 90 dB | | 90 dB | | | 90 dB | |
| Digitization | 10 Bit | | | 10 Bit | | 10 bit | | | 10 Bit | |
| Sensitivity | 9.6 V/lux.s @ 525 nm | | | 5.56 V/lux.s @ 550 nm | | 8 V/lux.s @ 525 nm | | | 4.64 V/lux.s @ 550 nm | |
| Sensor Algorithm | MAX, TRSH, COG, FIR-PEAK | | | MAX, TRSH, COG, FIR-PEAK | | MAX, TRSH, COG, FIR PEAK | | | MAX, TRSH, COG, FIR-PEAK | |
| Profile Length in 3D Mode | 1280 Pixels per Profile | | | 2048 Pixels per Profile | | 3072 Pixels per Profile | | | 4096 Pixels per Profile | |
| Typical Profile Speed Depending on Number of Sensor Rows | Sensor Rows | Profile Speed in kHz | | Sensor Rows | Profile Speed in kHz (with 2048 Pixels) | Profile Speed in kHz (with 3072 Pixels) | | Sensor Rows | Profile Speed in kHz (with 4096 Pixels) | |
| | | (with 1280 Pixels) | (with 688 Pixels) | | | C6-3070-GigE | C6-3070-WARP-GigE | | | |
| Height resolution can be increased by using TRSH (1/2 Pixel) or COG/FIR-PEAK (1/64 Pixel) without loss of speed | 1024 | 1.1 | 1.9 | 1024 | 0.3 | 1020 | 1.0 | 9.2 | 3072 | 0.2 |
| | 256 | 4.3 | 7.7 | 256 | 1.4 | 384 | 2.6 | 22.9 | 512 | 0.9 |
| | 128 | 8.5 | 15.1 | 128 | 2.6 | 192 | 5.1 | 42.1 | 128 | 3.1 |
| | 32 | 32.8 | 54.2 | 32 | 9.7 | 48 | 17.8 | 88.9* | 32 | 9.7 |
| | 16 | 63.0 | 95.7 | 16 | 16.0 | 12 | 47.9* | 88.9* | 16 | 14.9 |
| 8 | 116.0* | 155.2 | 8 | 25.0 | 6 | 66.5* | 88.9* | 8 | 20.3 | |

*limited due to the 1 Gbit/s interface, faster profile rates are possible with upcoming NBASE-T interface

| General C6 Camera Specifications | |
|----------------------------------|--|
| Interface Specifications | |
| Digital Input | 2 Electrical Isolated Inputs (5-24 V DC) |
| Digital Outputs | 2 Electrical Isolated Outputs (5-24 V DC) |
| Encoder / Resolver Input | High-Speed Resolver Interface with Signals A, /A, B, /B, Z, /Z |
| Analog Output | Range: 0-5 V DC |
| Data Interface | GigE Vision with GenICam Protocol |
| Power Requirements | |
| Power Supply | 10 - 24V DC |
| Power Consumption | max. 12 W |
| Mechanical Specifications | |
| Lens Mount | M42×1 / optional with C-Mount or F-Mount Adapter |
| Size | 55 mm x 55 mm x 55 mm (2.16 × 2.16 × 2.16 in) |
| Mass (without Lens & Adaptor) | 200 g |
| Housing Mount | M3 + Adaptor Plate with Metric and Inch Threads |
| Environmental Specifications | |
| Operating Temperature | 0°C to +40°C (+32 to +104 °F) (Non-Condensing) |
| Storage Temperature | -20°C to +80°C (-4 to +176 °F) |
| General | |
| PC Requirements | Gigabit Ethernet NIC |
| Operating Systems | Windows 10 /11, Linux |

With Default Lens Mount M42×1

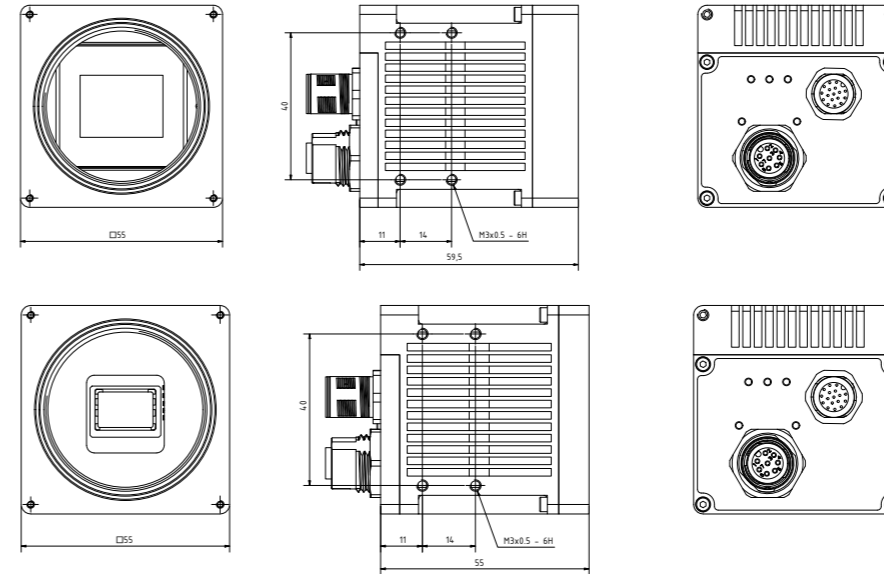

C6-4090-GigE

**C6-1280-GigE
C6-2040-GigE
C6-3070-GigE
C6-3070-WARP-GigE**

With C-Mount Adapter

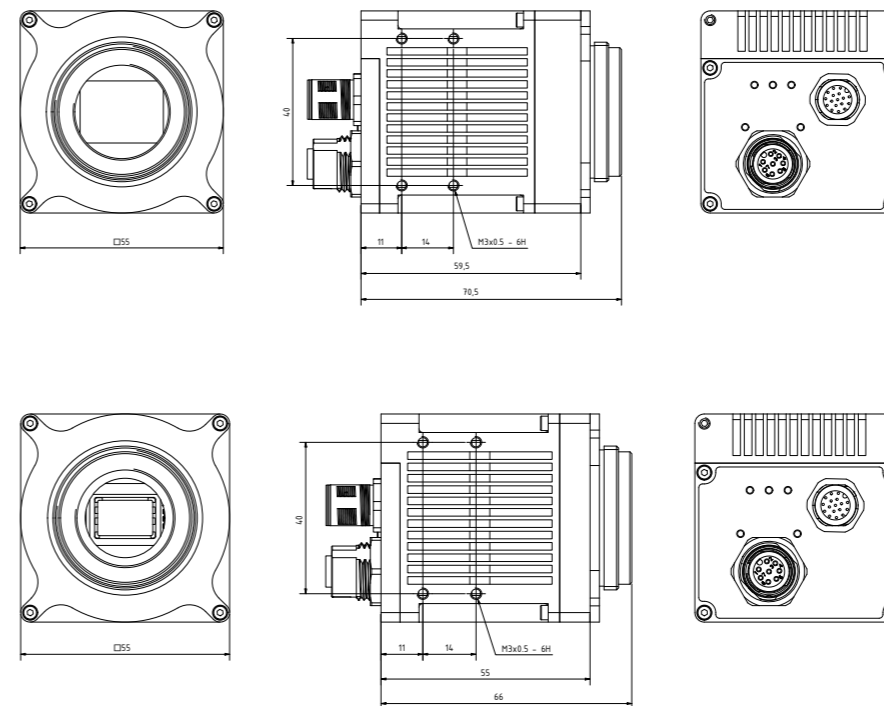

C6-4090-GigE

**C6-1280-GigE
C6-2040-GigE
C6-3070-GigE
C6-3070-WARP-GigE**

C7 CA CAMERA

Designed for flexible laser triangulation set-ups with user-defined lasers and lenses.

Available Models:

- ✓ C7-S8-3070-CA-S0*-T-5G: 3072 x 1020 pixels
- ✓ C7-S8-3070W-CA-S0*-T-5GT: 3072 x 1020 pixels with WARP

* All models available with integrated Scheimpflug 0°, 5°, 8.5°, 10°



New connector layout for direct laser connection



With different tubus options

Good to know:

- ✓ Designed for flexible laser triangulation set-ups with user-defined lasers and lenses
- ✓ 5 times higher data throughput thanks to 5 Gigabit/s
- ✓ New laser interface for connecting common laser line projectors
- ✓ Available with TFL and C-mount and integrated Scheimpflug arrangement
- ✓ Lens protection tubes
- ✓ Simultaneous output of multiple different features

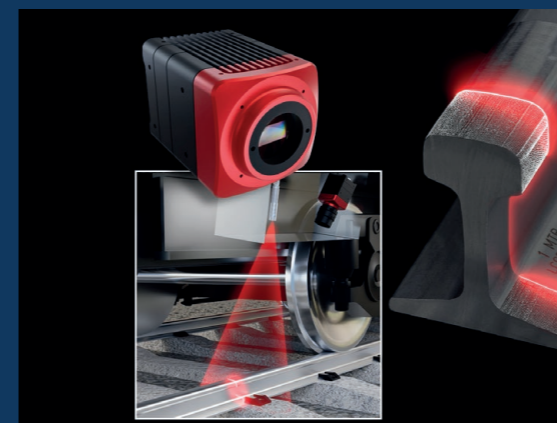

Recommended Applications:

- ✓ Advanced Packaging
- ✓ Road Scanning
- ✓ Railway Inspection

| | | | |
|---|---------------------------------------|---------------------------------------|-------------------------------------|
| Model Name | C7-3070 / C7-3070W | | |
| Sensor Resolution | 3072 × 1020 | | |
| Pixel Size | 6.6 μm x 6.6 μm | | |
| Dynamic Range (*with HDR-3D) | 90 dB | | |
| Digitization | 10 Bit | | |
| Sensor Algorithm | MAX, TRSH, COG, FIR-PEAK | | |
| Profile Length in 3D Mode | 3072 Pixels per Profile | | |
| Typical Profile Speed Depending on Number of Sensor Rows | Sensor Rows | Profile Speed in kHz | Profile Speed in kHz (WARP4) |
| Height resolution can be increased by using TRSH (1/2 Pixel) or COG/FIR-PEAK (1/64 Pixel) without loss of speed | 1021 768 384 192 96 48 | 0.9 1.3 2.6 5 9.7 17.8 | 9.1 12 22.9 42 72 94 |

| | |
|----------------------------------|--|
| General C7 Camera Specifications | |
| Interface Specifications | |
| Digital Input | 2 Electrical Isolated Inputs (5-24 V DC) |
| Digital Outputs | 2 Electrical Isolated Outputs (5-24 V DC) |
| Encoder / Resolver Input | High-Speed Resolver Interface HTL/TTL/RS422 with Signals A, /A, B, /B, Z, /Z |
| Analog Output | Range: 0-5 V DC |
| Data Interface | GigE Vision with GenICam Protocol, 5GBase-T |
| Power Requirements | |
| Power Supply | 10 - 24V DC |
| Power Consumption | max. 15 W |
| Mechanical Specifications | |
| Lens Mount | TFL-Mount, optional with C-Mount |
| Size | 79,8 mm x 55 mm x 55 mm (3.14 × 2.16 × 2.16 in) |
| Mass (without Lens & Adaptor) | 350 g |
| Housing Mount | M3 + Adaptor Plate with Metric and Inch Threads |
| Environmental Specifications | |
| Operating Temperature | 0°C to +40°C (+32 to +104 °F) (Non-Condensing) |
| Storage Temperature | -20°C to +80°C (-4 to +176 °F) |
| General | |
| PC Requirements | Gigabit or 5G Ethernet Interface |

Technical Drawings

Mechanical dimensions

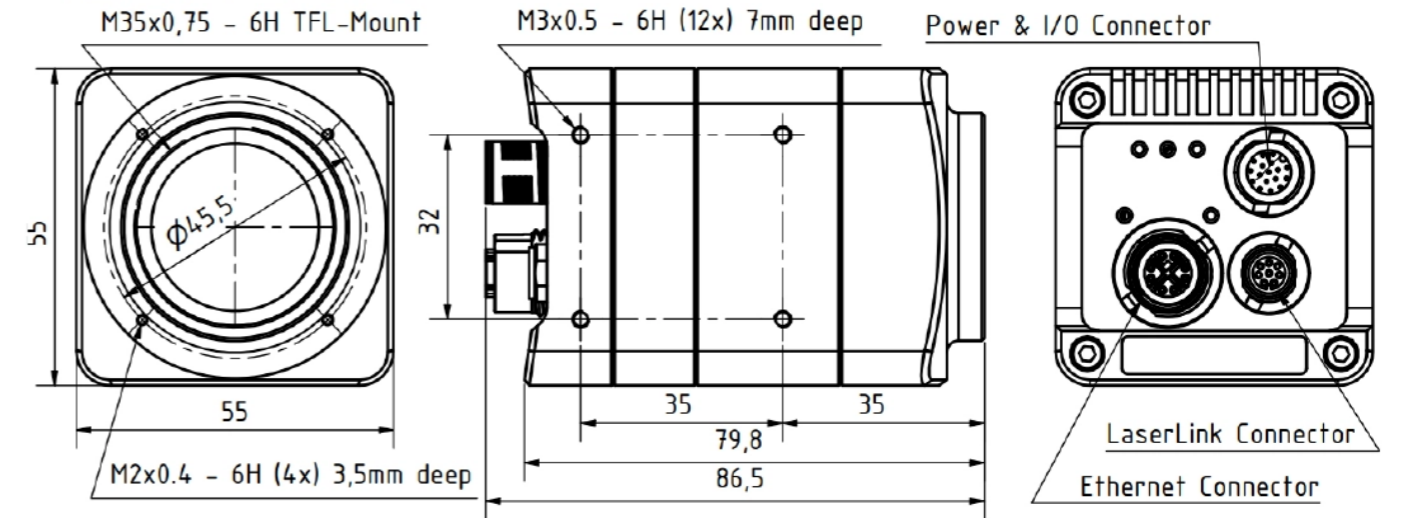

Connector layout and pin assignment

Power & I/O Connector: M12 17-Pin A-Coded Male

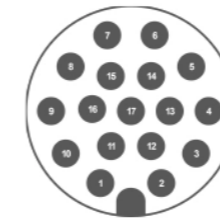

| | | |
|--------|---------|---|
| 1 | Z- | Encoder input Z- (RS-422, D-HTL) |
| 2 | L-VCC | Laser supply voltage (5-24V DC) |
| 3 | Z+ | Encoder input Z+ (RS-422, TTL, D/SE-HTL) |
| 4 | B+ | Encoder input B+ (RS-422, TTL, D/SE-HTL) |
| 5 | GND | Camera and Laser supply ground |
| 6 | B- | Encoder input B- (RS-422, D-HTL) |
| 7 | A- | Encoder input A- (RS-422, D-HTL) |
| 8 | VCC | Camera supply voltage |
| 9 | GND | Camera and Laser supply ground |
| 10 | A+ | Encoder input A+ (RS-422, TTL, D/SE-HTL) |
| 11 | IN-GND | Reference ground for Encoder/Digital inputs |
| 12 | OUT2 | Digital output 2, level defined by OUT-VCC |
| 13 | IN1 | Digital input 1 (5-24V DC) |
| 14 | IN2 | Digital input 2 (5-24V DC) |
| 15 | OUT-VCC | Output supply voltage (5-24V DC), refers to OUT-GND |
| 16 | OUT1 | Digital output 1, level defined by OUT-VCC |
| 17 | OUT-GND | Reference ground for digital outputs |
| Shield | SHIELD | Connected to device housing |

Ethernet Connector: M12 8-Pin X-Coded Female

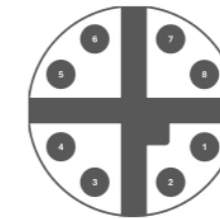

| | | |
|--------|--------|-------------------------------|
| 1 | MDI1+ | Data Pair 1, positive contact |
| 2 | MDI1- | Data Pair 1, negative contact |
| 3 | MDI2+ | Data Pair 2, positive contact |
| 4 | MDI2- | Data Pair 2, negative contact |
| 5 | MDI4+ | Data Pair 4, positive contact |
| 6 | MDI4- | Data Pair 4, negative contact |
| 7 | MDI3+ | Data Pair 3, positive contact |
| 8 | MDI3- | Data Pair 3, negative contact |
| Shield | SHIELD | Connected to device housing |

LaserLink Connector: M8 8-Pin A-Coded Female

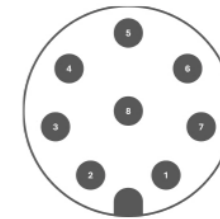

| | | |
|--------|--------|---|
| 1 | GND | Camera and Laser supply ground |
| 2 | VCC | Fused camera supply voltage output (5-24V DC) |
| 3 | L-VCC | Fused laser supply voltage output (5-24V DC) |
| 4 | AO | Analog output (0-5V) |
| 5 | DO | Digital output (5V) |
| 6 | TX | Transmit data output (RS-232) |
| 7 | RX | Receive data input (RS-232) |
| 8 | DI/AI | Digital/Analog input (0-5V) |
| Shield | SHIELD | Connected to device housing |

INTEGRATE

AT SolutionPackage

EASILY

The AT SolutionPackage consists of a variety of tools that can be used to acquire 3D images, configure the 3D camera and provide 3D data in the form of range maps or point clouds and more. This package is a software add-on to our 3D products.

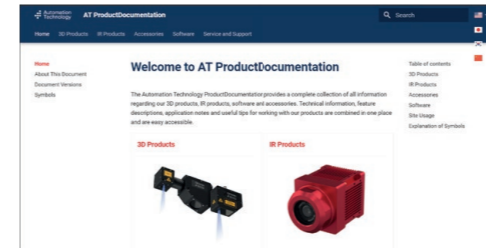

AT ProductDocumentation

- ✓ Complete documentation for all AT products including full support
- ✓ Easily accessible HTML documentation
- ✓ Offline version included

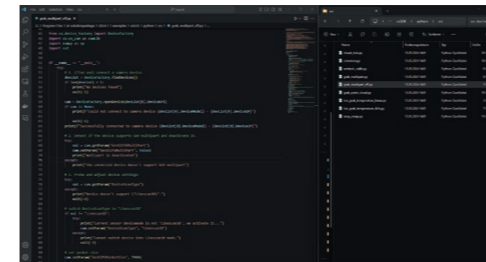

cxSDK

- ✓ SDK for image acquisition and camera configuration
- ✓ SDK for intrinsic and extrinsic calibration
- ✓ 3D point cloud and ZMap generation

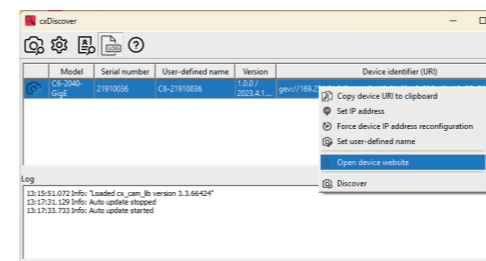

cxDiscover

- ✓ GigE Vision device discovery tool
- ✓ Network settings configuration

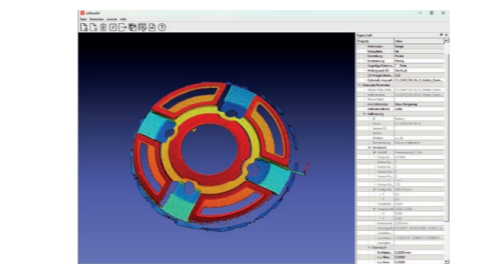

cxShow3D

- ✓ Sample tool with GUI for 3D point cloud visualization and ZMap generation

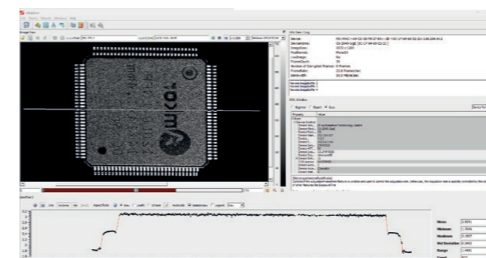

cxExplorer

- ✓ Software for 3D image acquisition, device configuration and data analysis

EVALUATE RAPIDLY

AT MetrologyPackage

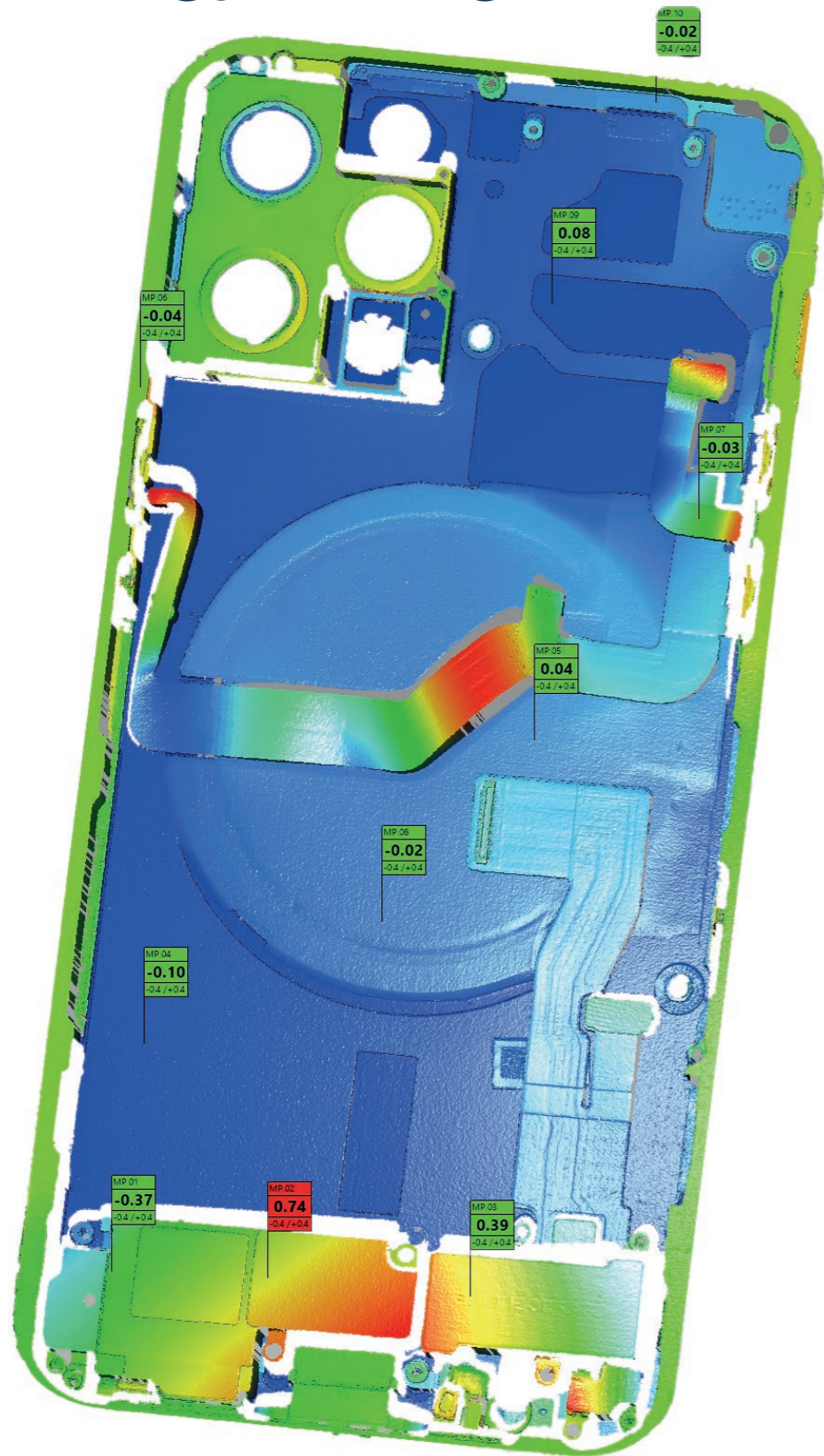

Our Smart 3D Software Add-on

- ✓ Easy to use software package for super-fast prototyping and deployment
- ✓ Simplified multi-sensor calibration
- ✓ Inline inspection per Reference Point System (RPS)
- ✓ Intelligent algorithms for 3D point cloud processing
- ✓ Includes GUI tool, source code and 3D sample data
- ✓ Basic version is free of charge
- ✓ Comprehensive developer version and runtime license available

Metrology Application Examples

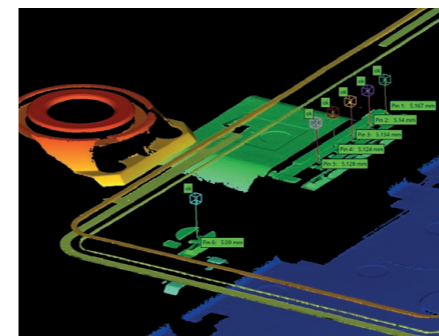

Pin Inspection

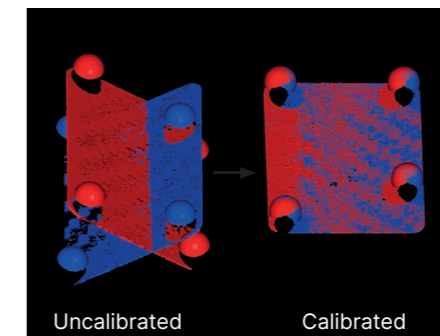

Multi-Scanner Calibration

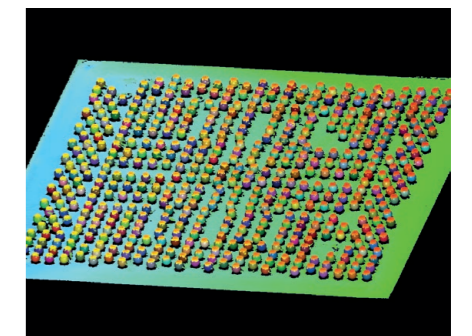

BGA Inspection

3D Measurements in Under 10 Minutes!

Fast + Easy
3D Software

- 1 **Install** AT SolutionPackage
- 2 **Scan** object
- 3 **Visualize** measurement data
- 4 **Design** evaluation

Improve your Multi-Scanner Calibration

- ✓ Four models depending on field of view
- ✓ Easy multi-scanner calibration
- ✓ Improved measurement quality
- ✓ Correction of linear transportation error

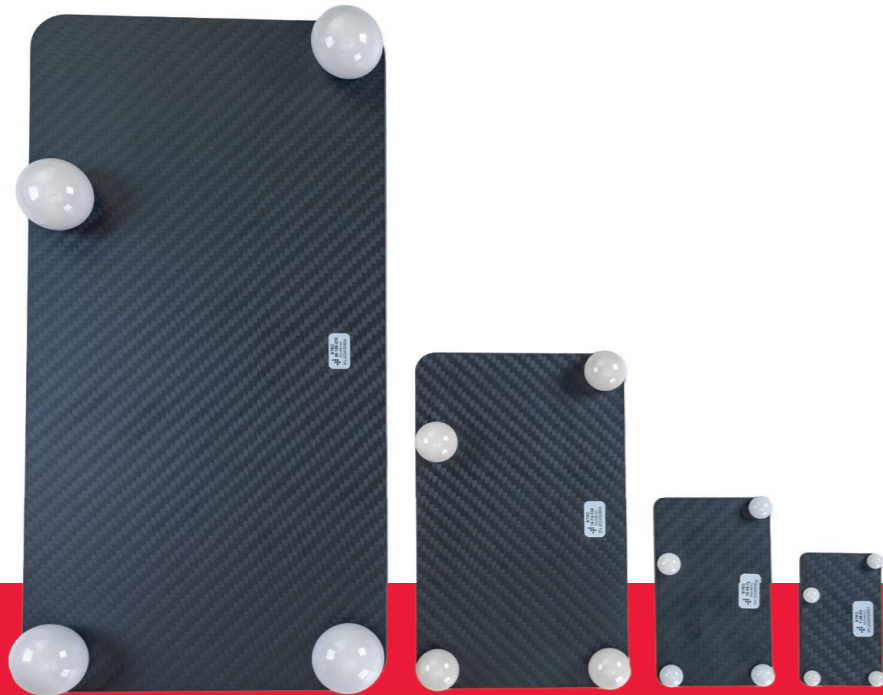

MetrologyPackage

Create your 3D processing prototype within 10 minutes

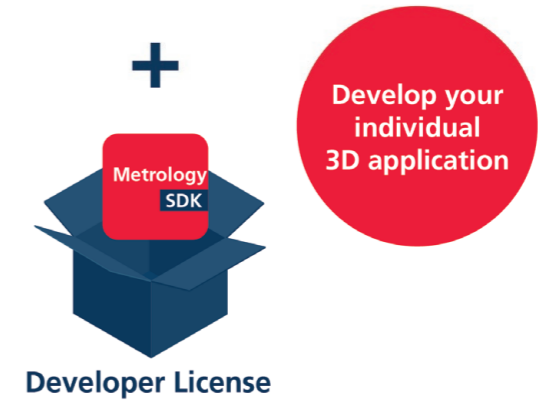

Develop your Customer-Specific Application

3D METROLOGY SOLUTION

PREVIOUS

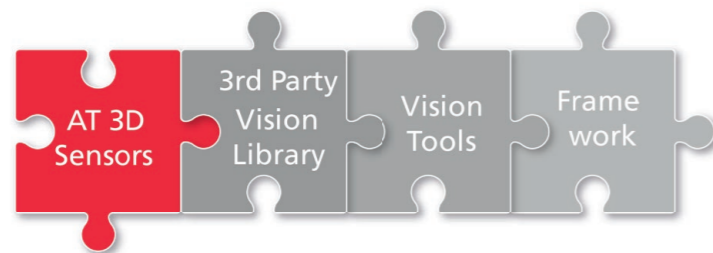

Usual way to your individual solution

NOW

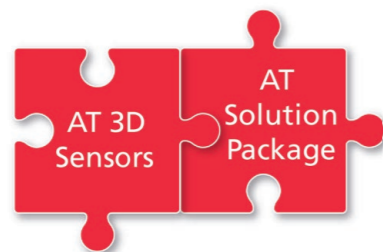

Easy way to your individual solution



"The ultimate 3D Metrology Solution is like a 'puzzle' and we have all parts now!"

André Kasper, AT CTO



Developer License

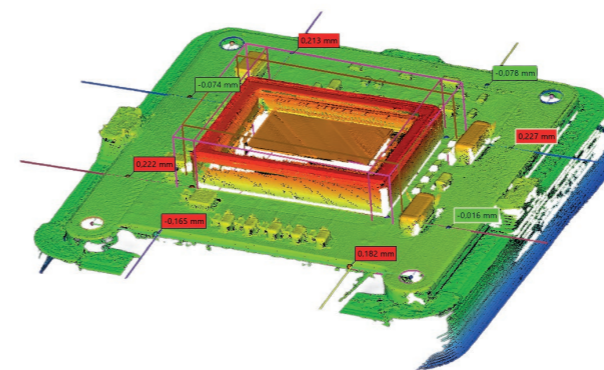

Your Benefits Using the Developer License

- ✓ Build your own complete software solution
- ✓ Use this software solution for your own measurement tasks
- ✓ Integrate your measurement task into your application
- ✓ Optimized for metrology applications

Individual Design for Every Measurement Task



Learn more about our **Laser Profile Sensors:**
www.at-sensors.com



AT - Automation Technology GmbH
Hermann-Boessow-Str. 6-8
23843 Bad Oldesloe
Germany

Phone: +49 (0)4531 88011-66
Email: sales@at-sensors.com
Web: www.at-sensors.com