



XCS SERIES

The Benefits:

- Unique 3D scan results without occlusion due to **dual-head option** and extremely **high profile speed of 3072 or 4096 points per profile**
- **High precision** and repeatability thanks to **high-quality laser line projection**
- **Unrivalled optical resolution** for electronic inspection (e.g. BGA inspection) with a field of view of up to 53 mm
- **Highest inspection speed** available with 3070 WARP sensor



All information here!
www.at-sensors.com

XCELLENT. XACT. XCS.

General Specifications for all XCS Models

Interface	Gigabit Ethernet (1GigE)
Inputs	<ul style="list-style-type: none"> Encoder A+, A -, B+, B -, Z+, Z- (TTL Level) Two freely configurable digital inputs (+5 to +24 VDC)
Outputs	Two freely configurable digital outputs (+5 to +24 VDC)
Power Supply	<ul style="list-style-type: none"> Sensor supply +10 to +24 VDC (max. +27 VDC) Laser supply +10 to +24 VDC
Housing	Anodized aluminum, IP67
Environmental Conditions	<ul style="list-style-type: none"> Operating temperature 0 °C to +40 °C Storage temperature -20 °C to +80 °C Humidity 20% to 80%
Vibration/Shock	<ul style="list-style-type: none"> Vibration resistance (sinusoidal): DIN EN 60068-2-6: 2008-10: 2g, 10-150 Hz Vibration resistance (random): DIN EN 60068-2-64: 2020-09: 7g, 10-500 Hz Shock resistance: DIN EN 60068-2-27: 2010-02: 15g, 3ms
Communication Protocols	GenICam, GigE Vision
Features	Automatic RegionTracking, Automatic RegionSearch, Multiple Regions, MultiPart, AutoStart, History Buffer, Multi-Slope, MultiPeak

Laser Specifications for all XCS Models

Laser Wavelength	405 nm
Laser Class	3R

Models 3070 / 3070 WARP

Part Number / Model Name	602344999 / C6-3070W-XCS-48-146-D-405-3R 602345000 / C6-3070W-XCS-48-146-S-405-3R 602345001 / C6-3070-XCS-48-146-D-405-3R 602345002 / C6-3070-XCS-48-146-S-405-3R
---------------------------------	--

Optical Setup 3070 / 3070 WARP

Lateral Resolution X	0,016 mm
Height Resolution Z	0,5 µm (with 6 subpixels)
Working Distance	146 mm
X-Field of View	48 mm
Profile Resolution	3072 pixel per profile
Profile Speed	max. 140 kHz, 14.5 kHz @ full Z-Range
Z-Range Near to Far	20 mm

Models 4090

Part Number / Model Name	602344997 / C6-4090-XCS-53-146-D-405-3R 602344998 / C6-4090-XCS-53-146-S-405-3R
---------------------------------	--

Optical Setup 4090

Lateral Resolution X	0,013 mm
Height Resolution Z	0,42 µm (with 6 subpixels)
Working Distance	146 mm
X-Field of View	53 mm
Profile Resolution	4096 pixel per profile
Profile Speed	max. 20.3 kHz
Z-Range Near to Far	10 mm

Technical Drawings Dual Head

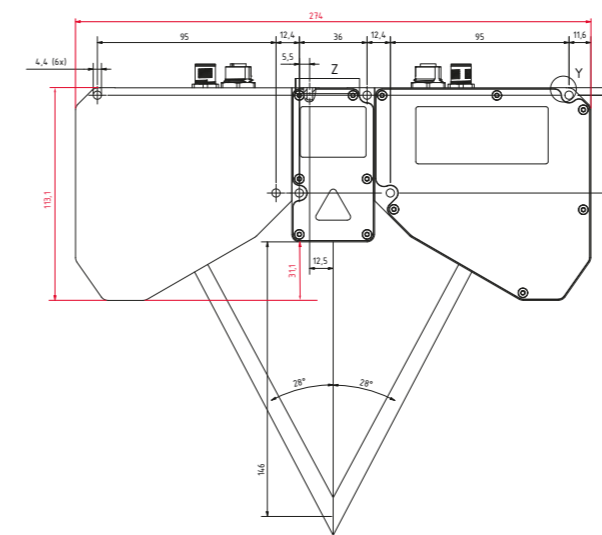

XCS 3070 / 3070 WARP

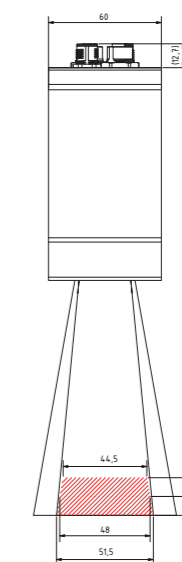

XCS 4090

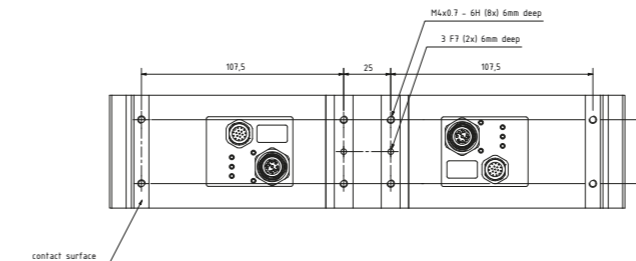
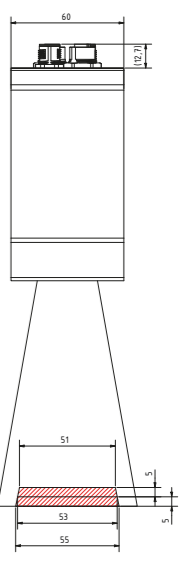

Technical Drawings Single Head

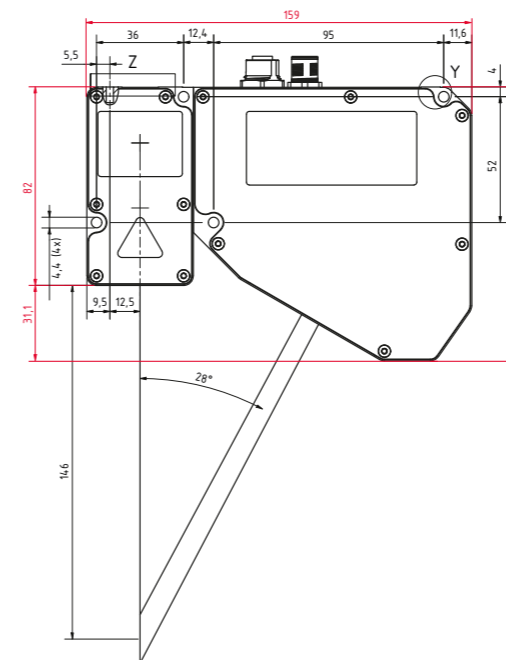

XCS 3070 / 3070 WARP

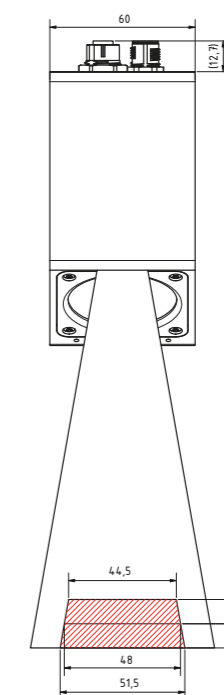

XCS 4090

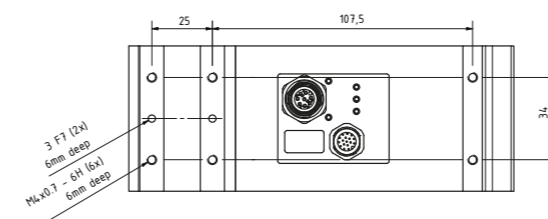
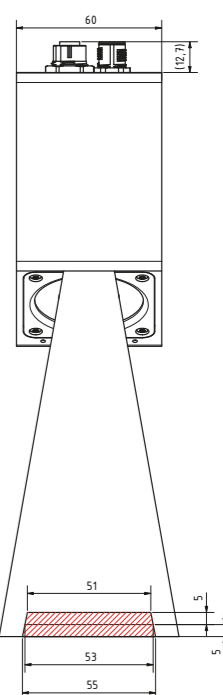

Small Field of View, Big Impact: New XCS Sensor from AT Transforms the Electronics Industry

In the semiconductor industry, it is the smallest details that make the difference between success and failure. With its new 3D sensor from the recently developed XCS series, AT – Automation Technology is launching a product onto the market that is a real game changer, especially for high-performance applications in the electronics industry.

The decisive arguments for this are above all its optimized laser and its very small field of view of up to 53 millimetres. The most important feature of the XCS series laser is the homogeneous thickness along the laser line thanks to the laser projector's special optics. The homogeneous line thickness enables precise scanning of the smallest structures – regardless of whether the object to be scanned is in the middle or at the edge of the line. The particular benefit for the customer: the development of inspection applications with high repeatability and exceptional accuracy, which means a real breakthrough in terms of precision for the inspection of ball grid arrays (BGAs), for example.

An equally decisive advantage is the Clean Beam function developed by AT. This protects the laser from external interference factors such as optical anomalies, so that the laser beam is both very precise and extremely focused. In addition, Clean Beam also enables a uniform intensity distribution, which in turn ensures reliable and consistent results.

The unrivaled performance of the XCS sensor is further enhanced by its dual-head option. This delivers unique 3D scanning results by eliminating occlusions while providing unparalleled high resolution at extreme speed. The 3070 WARP version of the sensor achieves profile speeds of up to 140 kHz, allowing the data volumes of the 3D scans to be analyzed particularly quickly and efficiently.

With the new 3D sensor from the XCS series, AT-Automation Technology is once again underlining its role as a pioneer in automation technology. The sensor is available immediately and promises to become an indispensable product for many electronics applications.

Focus Applications:

- Electronic Component Inspection (BGA, LGA, PGA)
- Electronic Assembly Inspection
- Connector Pin Inspection

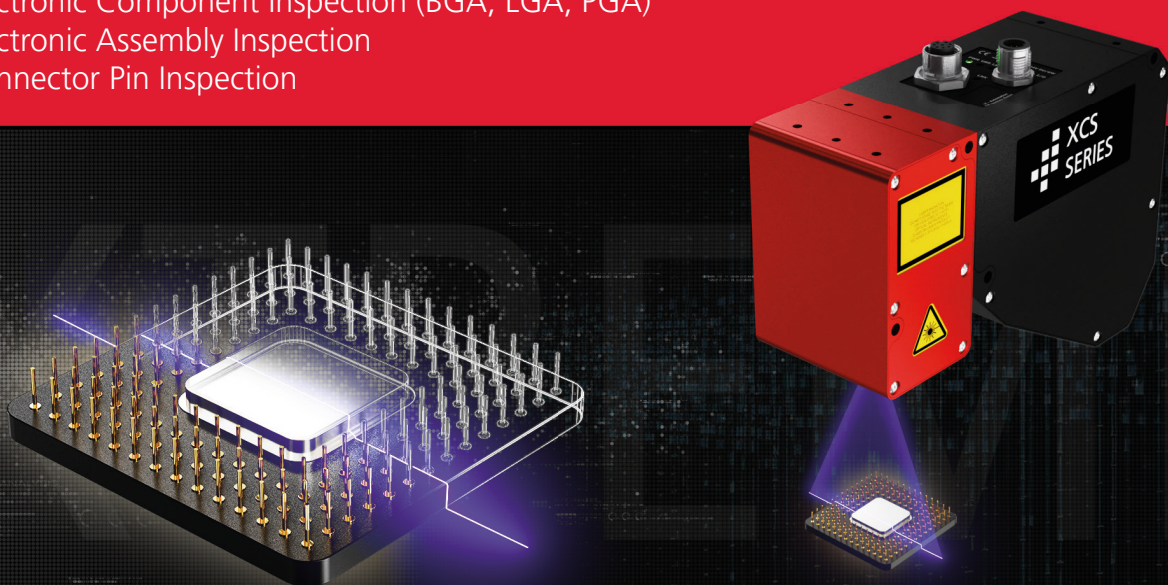

AT – Automation Technology

Hermann-Boessow-Str. 6-8
23843 Bad Oldesloe
Germany

Phone: +49 (0)4531 88011 - 66
Email: sales@at-sensors.com
Web: www.at-sensors.com

 Automation
Technology